

August 19, 2016

PECAN WOODS
DEVELOPMENT AGREEMENT
CITY OF KYLE, TEXAS

Effective as of August 17, 2016

PECAN WOODS DEVELOPMENT AGREEMENT

THE STATE OF TEXAS	§
	§
HAYS COUNTY	§

This PECAN WOODS Development Agreement (the “Agreement”) is made and entered into by and among the CITY OF KYLE, TEXAS, a Texas municipal corporation and home rule city located in Hays County, Texas, acting by and through its duly authorized Mayor (the “City”); and WALTON TEXAS, LP, a Texas limited partnership (“Walton Texas”), WALTON PECAN WOODS, LP, a Delaware limited partnership (“Walton Pecan Woods”), and WPW Development Sub, LP, a Delaware limited partnership (“WPW” and, together with Walton Texas and Walton Pecan Woods, the “Owners”), on the other hand. The City and Owners are sometimes collectively herein referenced as the “Parties”, and individually, as a “Party”.

RECITALS

A. Owners own approximately 762.77 acres of land located in Hays County, Texas, contained within the area described in the attached **Exhibit A** (“Pecan Woods” or the “Property”). Pecan Woods is partially located in the City’s extraterritorial jurisdiction (“ETJ”), and also partially located within its corporate limits. **Exhibit A-1**, “Jurisdiction Map” details the area of the Property located within the City of Kyle’s corporate limits.

B. Owners plan to develop Pecan Woods as a master-planned mixed use community which may include single family and multifamily residential units, commercial development and office development (the “Project”), as delineated on the Land Use Plan (as hereinafter defined) and attached as **Exhibit B**.

C. Owners and City intend that the Property be developed as a high-quality, master-planned, mixed use community, including parkland, open space, and other public and private amenities for the present and future benefit of the City pursuant to development regulations contained in this Agreement. A memorandum of this Agreement, in the form attached hereto as **Exhibit G**, will be recorded in the deed records of Hays County at Owner’s expense (so as to bind Owner and its successors with respect to the Property), and will provide regulatory certainty during the term of this Agreement.

D. Contemporaneously herewith the City has created a public improvement district (PID), which will include all or a portion of the Property boundaries in order to finance utility, roadway and drainage infrastructure to support the development in a financially feasible manner in accordance with Texas Local Government Code Chapter 372 and any applicable state law.

E. Owner and City have held discussions regarding the long term development of Pecan Woods, and desire to define, protect and clarify City’s jurisdiction and regulatory authority with respect to Pecan Woods through this Agreement.

F. The Owner desires to enter into an agreement with the City to establish certain restrictions and commitments imposed and made by the Parties in connection with the development of Pecan Woods; to provide increased certainty to Owner and City concerning the development approval process and the development requirements of the City for a period of years; and to identify land uses and other aspects of the development of Pecan Woods in the form of this Agreement which is promulgated under Section 172 of Chapter 212 of the Texas Local Government Code.

G. Pursuant to Section 242.001(a)(3) of the Texas Local Government Code City has concurrent jurisdiction with the County over subdivision platting and all related permits for the portion of the Property in the ETJ. A 1445 Interlocal Agreement ("1445 Agreement") between the City of Kyle and Hays County provides for the joint regulation of subdivision and approval of Pecan Woods as amended by the Tri-Party Agreement.

NOW, THEREFORE, for and in consideration of the mutual agreements, covenants, and conditions contained in this Agreement, and other good and valuable consideration, City and Owner agree as follows:

ARTICLE I
DEFINITIONS

Section 1.01 Terms Defined in this Agreement. In this Agreement, each of the following terms shall have the meanings indicated:

"Pecan Woods" or "Property" shall have the meaning set forth in the recitals to this Agreement, and consists of the land described on Exhibit A.

"City" shall mean the City of Kyle, Texas, a Texas home rule city.

"City Council" shall mean the City Council of the City or any successor governing body.

"City Manager" shall mean an official appointed as the administrative manager of the City.

"City Code" shall mean the approved City of Kyle ordinances in effect on the Effective Date and anything else incorporated by reference in this Agreement.

"Designated Successors and Assigns" shall mean an entity to which an Owner assigns (in writing) all or a portion of its rights and obligations contained in this Agreement pursuant to Section 13.05(a).

"Development Waivers" shall mean a deviation from City Code as set forth on Exhibit D.

"Director" shall mean the Director of the City's Planning Department, or its successor department.

"Effective Date" and similar references shall mean the date defined in Section 13.01.

“Emergency First Response Site” shall mean a one-acre site to be used for emergency services as set forth in Section 4.09.

“Extraterritorial Jurisdiction” or “ETJ” shall mean that geographic area outside the corporate boundaries of the City as established pursuant to V.T.C.A., Local Government Code § 42.021 and 42.022.

“Land Use Districts” shall mean the land use categories for property within Pecan Woods, as shown on **Exhibit C**.

“Land Use Plan” shall mean the land use plan for Pecan Woods attached as **Exhibit B**, as it may be amended from time to time in accordance with this Agreement.

“Open Space” shall mean private property under common ownership designated for recreational use, including a private park, play lot, plaza or ornamental area intended for use or enjoyment of property owners within a subdivision. Open space does not include streets, alleys, utility easements, public parks or required setbacks.

“Owners” or “Owner” shall have the meaning specified in the opening paragraph.

“Parks Plan” shall mean the parks, trails and open space plan attached as **Exhibit E** and further described on **Exhibit E-1** and **Exhibit E-2**.

“Pecan Woods Public Improvement District” means the public improvement district created by the City pursuant to Texas Local Government Code, Chapter 372 on the Property.

“Phase One” that portion of the Property described as Phase One on **Exhibit B-1**.

“Phase Two” that portion of the Property described as Phase Two on **Exhibit B-1**.

“Phase Three” that portion of the Property described as Phase Three on **Exhibit B-1**.

“Phase Four” that portion of the Property described as Phase Four on **Exhibit B-1**.

“Phase Five” that portion of the Property described as Phase Five on **Exhibit B-1**.

“Project” shall mean the master-planned mixed use community as delineated on the Land Use Plan attached as **Exhibit B**.

“Property” shall mean approximately 762.77 acres of land located in Hays County, Texas, contained within the area described in the attached **Exhibit A**.

“Site Development Regulations” shall mean those regulations applicable to the Project as described in **Exhibit C**.

“Tri-Party Agreement” shall mean that certain Tri-Party Agreement to be entered into between the Owner, City and Hays County regarding dual jurisdiction of Hays County and the City over the portion of the Project in the ETJ.

ARTICLE II
JURISDICTIONAL AUTHORITY AND VESTING RIGHTS

Section 2.01 Consent to Future Annexation. Owners and all subsequent owners of property within Pecan Woods voluntarily consent to annexation by the City upon the terms and conditions set forth in this Agreement. Notice to all subsequent owners of the property shall be evidenced by the Memorandum of Agreement attached as Exhibit G which will be recorded in the deed records of Hays County. Additionally, a note covering the foregoing will be added to all final subdivision plats.

Section 2.02 Jurisdiction. Pursuant to the authority of Section 242.001(a)(3) of the Texas Local Government Code, the City has concurrent jurisdiction with Hays County over the review and approval of preliminary subdivision plats, final subdivision plats, and construction plans. Notwithstanding the foregoing, the parties acknowledge that such jurisdiction has been further defined and amended by the Tri-Party Agreement.

Section 2.03 Vesting Rights. The City acknowledges that the Owners shall be deemed vested from the Effective Date of this Agreement to develop Pecan Woods in accordance with this Agreement to the extent and for such matters as vesting is applicable pursuant to Chapter 245 of the Texas Local Government Code. To the extent any Site Development Regulations, Development Waivers and Land Use Districts, or the other criteria specified in this Agreement are in conflict with any other current or future City Code, then the Site Development Regulations, Development Waivers and Land Use Districts and other criteria in this Agreement shall prevail unless otherwise agreed to by the Owners in writing. A vested right under this Agreement shall not apply to regulations mandated by state law, or that are necessary to prevent imminent harm to human safety or property (including without limitation the fire code), which may be modified and made applicable to the Project even after the Effective Date.

Section 2.04 Owner's Rights to Continue Development. In consideration of Owner's agreements, the City agrees that it will not, during the Term of this Agreement, impose or attempt to impose: (a) any moratorium on building or development within Pecan Woods or (b) any land use or development regulation that limits the rate or timing of land use approvals, whether affecting subdivision plats, site development permits or other necessary approvals, within Pecan Woods except for moratoria imposed pursuant to Texas Local Government Code Subchapter E, Section 212.131 et. seq. This Agreement on the part of the City will not apply to temporary moratoriums uniformly imposed throughout the City and its ETJ due to an emergency constituting an imminent threat to the public health or safety, provided that the temporary moratorium continues only during the duration of the emergency.

ARTICLE III
LAND USE

Section 3.01 Regulations. All development within the Property shall generally comply with (i) the Land Use Plan attached hereto as **Exhibit B**, (ii) Site Development Regulations attached hereto as **Exhibit C**, (iii) the City Code (as modified by Development Waivers in **Exhibit D** and otherwise by this Agreement), and (iv) the other terms and conditions of this Agreement (including

the Exhibits).

Section 3.02 Land Use Districts. The Land Use Districts shown on the Land Use Plan shall correspond to the applicable zoning districts in the City Code as categorized as “Low”, “Medium”, “Multifamily”, and “Commercial” on **Exhibit C**. Each Development Pod shown on **Exhibit B** will be allowed to follow the zoning regulations for any of the zoning districts listed under the applicable category on **Exhibit C**. For example, Development Pod 20 in **Exhibit B** is shown as “Low”, so it can be developed under City Code zoning districts R-1-1 or R-1-2. At the time any portion of a Development Pod is platted, the plat will designate which zoning district it will be developed under. It is hereby noted that (i) certain retail and other commercial uses will be permitted in the residential based Land Use Districts, subject to certain size and scale limitations described on **Exhibit C** and (ii) such nonresidential uses in a residential based Land Use District, if developed, are intended to be located at appropriate locations, such as along thoroughfare corridors or at the intersections of major thoroughfares, within the development, and (iii) residential uses (other than single-family detached) will be permitted in the commercial based Land Use Districts, as further detailed on **Exhibit C**.

Section 3.03 Mixed Use. Vertical mix of uses is encouraged within the Multifamily and Commercial Development Pods.

ARTICLE IV
LAND USE PLAN, APPLICABLE
DEVELOPMENT REGULATIONS AND RELATED MATTERS

Section 4.01 Phased Development. Owner intends to develop Pecan Woods in phases as shown in the Phasing Plan attached hereto as **Exhibit B-1**. Owner may change the phasing of development from time to time in response to market conditions or other factors. Phases may be developed concurrently. City acknowledges that the portions of the Property not under active development may remain in use for agricultural or ranching purposes and/or wildlife management.

Section 4.02 Groundwater Use. Owner may use all underground water and any other water from any and all depths and reservoirs, formations, depths and horizons beneath the surface of the Property (“Groundwater”) in accordance with state law and if necessary, with the approval of the current CCN holder for the area. Subject to obtaining any required permits or governmental authorizations, Owner may install water wells on the Property for the purpose of using the Groundwater.

Section 4.03 Land Use Plan. City hereby approves the Land Use Plan attached hereto as **Exhibit B**, which describes the Project. The City hereby approves the general use and development of Pecan Woods pursuant to the Land Use Plan, which describes the Project, and is attached hereto as **Exhibit B** and which may be subject to change as per Article IX.

Section 4.04 Controlling Ordinances, Manuals, and Rules. All of the City’s Codes are hereby adopted, as of the Effective Date of this Agreement, in their entirety subject to the regulations contained herein, including, without limitation, Site Development Regulations and Development Waivers attached hereto as **Exhibit C** and **Exhibit D**, respectively, and shall apply to the development of the Property. Neither Owner nor any subsequent owners shall be required to

comply with any City Codes which are inconsistent with this Development Agreement or the Development Waivers unless otherwise agreed to by the Owners in writing. Measures which the City must enact or enforce pursuant to state or federal mandates or court order may be enforced to the extent necessary to comply with state or federal law or court order.

Section 4.05 Term of Land Use Plan. Approval of the Land Use Plan for Pecan Woods will remain in effect for the Term of this Agreement, subject to the terms and conditions of this Agreement, regardless of whether all or any portion of Pecan Woods is annexed and zoned.

Section 4.06 Building Permits and Inspections. The City shall have the right to inspect the buildings, assess fees for inspections, and issue certificates of occupancy for any structure within Pecan Woods even though not annexed into the City as if the Property were in the City limits; provided, however, inspection fees shall not exceed fees for properties in the City limits.

Section 4.07 Parks, Trails and Open Space Dedication.

- a. Owner agrees to develop Pecan Woods in accordance with the Parks, Trails and Open Space Plan attached as **Exhibit E** and the descriptions contained in **Exhibit E-1**.
- b. Pecan Woods will be served by an Amenity Center in the appropriate location shown on **Exhibit E-2**, which will include improvements similar to those described in **Exhibit E-1** and be completed no later than the date of issuance of the one hundredth (100th) Certificate of Occupancy for the Project.
- c. A minimum of one hundred and seventy five (175) acres of parks and open space will be dedicated to the City within Pecan Woods.
- d. Owner will construct .6 miles of an eight foot (8') wide concrete hike and bike trail in the approximate location shown on **Exhibit E-2** no later than the date that the Second final plat within Phase One is approved.
- e. Owner will complete the following items no later than the date the last final plat within Phase One is approved.
 - i. Owner will dedicate approximately twenty eight (28) acres of parkland to the City, in the approximate location shown on **Exhibit E-2**.
 - ii. Owner will construct and dedicate to City a building as generally described in **Exhibit E-3** for use by the City's Parks and Recreation Department as a maintenance building (the "**Park Maintenance Building**"). The exact location of the Park Maintenance Building will be determined by Owner in cooperation with the City Parks and Recreation Department.
 - iii. Owner will provide an eight foot (8') wide public access easement for an additional approximate 1.9 miles of unpaved hike and bike trails, in the approximate location shown on **Exhibit E-2**. Note that the trail runs through all five phases of parkland.
- f. With each subsequent phase of development shown on **Exhibit B-1**, Owner will dedicate to the City the corresponding parkland located within the phase of parkland, and replace the unpaved hike and bike trails described in Subsection e(iii)

above, with eight foot (8') wide concrete trails. Dedication and construction will be as shown in **Exhibit E-2** and described below. In the event that the Project phasing is altered, as described in Section 4.01 above, the parkland may be dedicated (at the City's discretion) in sequential, contiguous phases instead of those associated with the corresponding phase of development. For example, if Phase Three of the Project is developed after Phase One of the Project, the City may elect to have the Owner dedicate the Phase Two Parkland (which is contiguous to the Phase One Parkland) in connection with the final plat of Phase Three.

- i. Phase Two Parkland shall be dedicated to the City and the portion of the eight foot (8') wide trail located in the Phase Two Parkland constructed no later than the date of approval of the last final plat within Phase Two.
 - ii. Phase Three Parkland shall be dedicated to the City and the portion of the eight foot (8') wide trail located in the Phase Three Parkland constructed no later than the date of approval of the last final plat within Phase Three.
 - iii. Phase Four Parkland shall be dedicated to the City and the portion of the eight foot (8') wide trail located in the Phase Four Parkland constructed no later than the date of approval of the last final plat within Phase Four.
 - iv. Phase Five Parkland shall be dedicated to the City and the portion of the eight foot (8') wide trail located in the Phase Five Parkland constructed no later than the date of approval of the last final plat within Phase Five.
- g. The Parkland to be dedicated pursuant to subparts (d), (e) and (f) above will contain a mix of the types of parks described in **Exhibit E-1**.
- h. Maintenance of parks, trails, facilities (including the Park Maintenance Building) and open space dedicated for public use to the City shall be the responsibility of the City, with the exception of a 13.1 acre community garden which shall be the responsibility of a to-be-formed homeowners association. All other parks, trails, and open space not dedicated to the City will be maintained by one or more homeowners associations. Note that the Amenity Center may be reserved for use only by some or all of the residents, tenants and invitees of the owners of the Property. Notwithstanding the foregoing, it is hereby agreed that until the 1.9 mile trail is paved and dedicated to the City, the HOA will maintain it (which will include mowing at a minimum).
- i. Owner reserves the right to retain access easements and/or utility easements located within any dedicated parkland or open space.

Section 4.08 Additional Development Standards.

- a. A six foot (6') masonry wall shall be constructed where residential lots abut public roadways (FM 150, Heidenreich and Grist Mill) external to the Project. Such wall may consist of one or more of the following materials: stone, brick, decorative concrete masonry unit, pre-cast concrete panels, or similar materials. The wall may taper at entry features.

- b. Where single family homes abut public roadways (FM 150, Heidenreich and Grist Mill) external to the Project, the rear façade of such homes shall consist entirely of brick, stone, stucco, or a combination of such materials except windows and doors.
- c. Where single family homes abut the main collector roadway within the Project, the rear façade of twenty five percent (25%) of such homes shall consist entirely of brick, stone, stucco, or a combination of such materials except windows and doors; provided, however, such 25% shall be interspersed throughout the given roadway.
- d. Portions of Pecan Woods may be gated pods. Masonry, metal, or similar quality fencing may be installed along the perimeter of the pods, provided that all public amenities and publicly-maintained infrastructure are located outside of the gated area.
- e. The Project shall be permitted to construct alley loaded garages for single family homes.
- f. The Project will be subject to comprehensive design criteria that will be detailed in design guidelines as referenced in the Declaration of Covenants, Conditions, and Restrictions (“CCRs”) to be established by the Owner. A set of CCRs will be recorded concurrently with the final plat for each Phase of the Project, or at Owner’s election, against the entire Project prior to or concurrently with the recordation of the final plat for Phase I of the Project. The following topics will be addressed in the CCRs subject to approval by the Director.
 - Future home builders within the project will have all product types (elevations) reviewed and approved by City of Kyle prior to issuance of building permits
 - All elevations of homes must be 100% masonry product (stone, brick, stucco, cementitious siding or other City approved masonry product or combination)
 - AC condensing units must be screened from view
 - Plans with the same elevation can only be repeated every third lot
 - Plans with the same elevation cannot be placed on a lot directly across the street from the same plan
 - Color pallets of proposed exterior (brick, stone, other masonry and etc.) has to be approved by the Developer/Architectural Control Committee (ACC) (note that Developer/Architectural Control Committee – or some other equivalent will be appropriately defined in the future CC&R document and are used herein to identify that obligation).
 - All exterior building materials must be approved by the ACC
 - Roof Pitch: a minimum of sixty five (65%) percent of the roof of the primary residence erected on a lot shall have a roof pitch of no less than 8:12 unless otherwise approved in advance by the ACC. The roof pitch of dormers, porches and other similar accessory structures attached to the primary residence shall be exempt for this requirement, but nonetheless subject to approval by the ACC.
 - Roofing Materials: shall be limited to material (composite shingles, tile, high quality metal) that has a rating of 30 years or more

- Energy Efficiency Roofing: roofs of buildings may be constructed with “Energy Efficiency Roofing” with the advance written approval of the ACC
- Fencing and Walls:
 - Lot fencing: fencing is required on the sides and rear of each lot
 - Obstruction of sight lines prohibited: no fence, wall or hedge or shrub planting that obstructs sight lines at elevations between 3’ and 6’ above the roadway shall be allowed on any corner lot.
 - Stain: any stained fences will be required to be stained using a stain that is approved in advance by the ACC
- Mailboxes: no single mailboxes, mailboxes will be grouped at various community locations with appropriate covering and lighting
- Windows: exterior shutters shall be sized appropriately
- Windows will have an architectural trim element
- Columns along the front exterior shall have a trim element
- Columns do not have to be masonry, but must be approved by ACC

Section 4.09 Site Dedications.

- a. **Emergency Response Site.** The Owners hereby agree with the City to dedicate to the Caldwell Hays County Emergency Service District (“ESD”) No. 1 (at no cost to the service provider) a one acre site within the Project to be used as an Emergency Response Site (the “Emergency Response Site”) to serve the surrounding community. The Emergency Response Site may be used at the discretion of the service provider for construction of a fire or emergency medical services facility (the “Facility”). The location of the Emergency Response Site shall be determined by Owner, and shall be located off of Heidenreich Lane or Grist Mill Road. The Emergency Response Site must have access to a public road and be in a location that would allow the Facility to provide the service it is intended for. Owner will dedicate the Emergency Response Site at such time as it is reasonably determined by Owner and the City that the Facility is needed to serve the community. The service provider shall be responsible for all costs related to the permitting, construction, maintenance, and operation of the Facility. If construction of the Facility is not completed within eight (8) years of the date hereof, instead of being used for emergency services, the Emergency Response Site may be developed consistent with surrounding use in accordance with the standards of the adjoining Land Use Districts. Notwithstanding the foregoing, Owner will notify the City one (1) year before the 8 year timeframe expires and if the City has a different public use for the site that is acceptable to Owner then at the expiration of the 8 year timeframe Owner shall dedicate the site to the City for such alternate public use.
- b. **Police Site.** The Owners hereby agree to dedicate to the City (at no cost to the City) a one acre site within the Project (the “Police Site”) to serve the surrounding community. The Police Site may be used at the discretion of the City for construction of a police station (the “Police Station”). The location of the Police Site shall be determined by Owner, but will be located off of Heidenreich Lane or Grist Mill Road in a location that would allow the Police Station to provide its intended services. Owner will dedicate the Police Site at such time as it is reasonably determined by Owner and the City that the Police Station is needed to

serve the community. The City shall be responsible for all costs related to the permitting, construction, maintenance, and operation of the Police Station. If construction of the Police Station is not completed within eight (8) years of the date hereof, instead of being used for police services, the Police Site may be developed consistent with surrounding use in accordance with the standards of the adjoining Land Use Districts.

Section 4.10 Permitting. City will expeditiously process and review all development applications, inspections and permits related to the development of the Property in accordance with the City Code (as modified hereby).

Section 4.11 Appeal Process. Any judgment on an application for approval by the Director or City Manager may be appealed to the City Council per City Code.

Section 4.12 Owners Association. Prior to the sale of any platted lots within Pecan Woods, Owner shall establish a mandatory, dues paying property owners association with an architectural control committee, which committee shall govern the architectural elements of all physical structures. The purpose of the association will be to ensure a consistent quality and appearance of improvements and to maintain landscaping and exterior features. During the time the declarant controls the HOA board (i) the Board will include at least one (1) homeowner and (ii) at least one (1) homeowner from every Phase of the Project will be on an advisory committee to the board.

ARTICLE V **UTILITIES**

Section 5.01 Water Service. Pecan Woods is currently located within the area covered by County Line Special Utility District (SUD). It is anticipated that County Line SUD will provide for water service for Pecan Woods.

Section 5.02 Wastewater Service. The City agrees to provide retail wastewater services to Pecan Woods in accordance with the following terms:

- a. **Capacity.** The City will provide up to 3,300 LUE capacity for wastewater for the Project. The remainder is not transferable, and the City may use any portion of unused capacity that remains after the Project is fully completed and occupied. Subject to Owner complying with its obligations in subpart (d) below, the City will complete any necessary plant expansions or other improvements necessary to provide such capacity in a timeframe necessary to meet the build-out schedule of the Project.
- b. **Off-Site Infrastructure.** In the event that Owner is required to build any off-site infrastructure to connect to the Plant Expansion, Owner shall be required to pay all design and construction costs with respect to infrastructure necessary to serve the Project. If, however, the City requests any oversizing of infrastructure, then within ninety (90) days of completion of that given component of the infrastructure the City shall reimburse Owner for its incremental share of the costs of the infrastructure compared to the infrastructure necessary to serve the Project. For

example, if a ten-inch (10") line is necessary to serve the Project, and the City requests a fifteen-inch (15") line, then the City shall be required to reimburse the Owner for the incremental cost difference between a ten-inch (10") line and a fifteen-inch (15") line.

- c. **Service Agreement.** The Parties will enter into a Retail Wastewater Service Agreement reflecting, among other things, the items set forth in this Section 5.02.
- d. **PID Bonds.** So long as the City approves the issuance of the PID bonds, or otherwise provides or approves an alternative infrastructure funding mechanism reasonably requested by the Owner, Owner shall:
 - i. Provide a sum of two million dollars (\$2,000,000) to the City toward expansion of the wastewater treatment plant within thirty (30) days after the later of: (i) the City approves construction plans associated with the final plat for the Phase One of the Project, (ii) approves a Service and Assessment Plan for the PID bonds.
 - ii. Construct at its cost a wastewater line through the Project and from the western property line of the Project to the wastewater treatment plant as approximately shown on **Exhibit H** attached hereto.
 - iii. Provide stub-outs for Simon Middle School and Hemphill Elementary School at such time as Owner builds the wastewater line described in subpart (ii) above of this Section 5.02(d).

So long as Owner has complied with the provisions of the PID Finance Agreement with respect to the issuance of PID bonds and the PID bonds are not issued within twelve (12) months after requested by Owner, then Owner shall receive wastewater impact fee credits equal to:

- i. Any portion of the \$2,000,000 contribution for the wastewater plant expansion described in subpart (i) of this Section 5.02(d) that have been paid by Owner; and
 - ii. An additional \$500,000 so long as the stub-outs described above in subpart (iii) above of this Section 5.02(d) have been made.
- e. **Required Easements.** All of the on-site wastewater facilities will be located either in the public right-of-way or in easements across privately-owned land. The Owner is responsible for obtaining any governmental approvals necessary to construct the on-site wastewater facilities in the public right-of-way or for acquiring any easements across privately-owned land that are necessary for the construction or operation of the on-site wastewater facilities except for capital improvements made by the City. All easements will be located in areas that are reasonably accessible to the City's personnel and equipment for repairs during wet weather conditions. Except as may be provided by the term of the easement, the Owner or its assignees shall not prevent the City from enacting construction, repairs or maintenance to on-site wastewater lines. The final location of an easement is subject to review and comment by the City.

Section 5.03 Irrigation. Irrigation lines installed within public right-of-way will be constructed of purple pipe in lieu of white PVC pipe, for future connection to re-use water.

ARTICLE VI **TRANSPORTATION**

Section 6.01 Roadways. Upon approval of this Agreement, City agrees that the arterial roadway network shown on the Land Use Plan will be incorporated into to the City's Transportation Master Plan only for the area covered by the Project. The City hereby agrees that streets can be designed in accordance with Article 5 of Chapter 41 of the Code of Ordinances (as modified by **Exhibit D**) and / or the Typical Cross Sections depicted on **Exhibit F** attached hereto.

Section 6.02 Dedication of Roadways. Owner intends to dedicate roadways within the Project to Hays County for maintenance until full purpose annexation by the City.

Section 6.03 Fruit Trees. Fruit-bearing trees shall not be planted within or along the right-of-way.

ARTICLE VII **ANNEXATION**

Section 7.01 Annexation.

- a. **Annexation of Residential Areas.** Pursuant to this Agreement, the City hereby agrees not to annex any phase of the Property designated for 'Residential' use until twenty (20) years after PID bonds for that particular phase of the Property have been issued. For example, if PID bonds are issued for a phase of the Property in 2020, the earliest the City could full purpose annex that particular phase of the Property would be 2040.
- b. **Time Frame to Issue Bonds.** Owner hereby agrees that all PID bonds for the Property will be issued within thirty (30) years of the Effective Date.
- c. **Disannexation of Residential Areas.** A certain portion of the Property identified on **Exhibit A-1**, was annexed into the City prior to the execution of this Agreement. The portion of the Property identified on **Exhibit A-1** which is designated for 'Residential' uses on the Land Use Plan attached as **Exhibit B** shall be disannexed, save and except a five foot (5') strip adjacent to FM 150, at the time of final plat of any portion of such property. At the time of disannexation, the terms and conditions of this Agreement shall apply to such disannexed property and the disannexed property shall be developed in accordance with the Land Use Plan. Such disannexed Residential Use property will be annexed in the future in accordance with terms and conditions of subparagraph (a) above.
- d. **Annexation of Commercial Areas.** The portion of the Property identified on **Exhibit A-1** which is designated for 'Commercial' use on the Land Use Plan shall remain within the corporate limits of the City. Notwithstanding the terms of

subsection (a) above, all portions of the Property designated for 'Commercial' use, which have not already been annexed, shall be annexed for full purposes into the City at the time of final plat of the applicable portion(s).

- e. **Zoning of Annexed Land.** Contemporaneously with the annexation of any land within Pecan Woods, the City will zone property within Pecan Woods consistently with the land uses set forth on the Land Use Plan (as modified by **Exhibit C**) and the other exhibits and terms of this Agreement. However, zoning for any developed property shall also be consistent with the land uses in existence on the date of the annexation insofar as practical.

The portion of the Property identified on **Exhibit A-1** which is designated for 'Commercial' use on the Land Use Plan (as referenced in subparagraph (c) of this Section 7.01), will be zoned for commercial use in accordance with the Land Use Plan and other terms and exhibits of the agreement simultaneously with the zoning of commercial land adjacent to it as such property is platted.

- f. **Multifamily.** For purposes of this section, 'Multifamily' shown on the Land Use Plan will be treated as a 'Residential' use.

ARTICLE VIII **ADDITIONAL PROJECT AREA**

Section 8.01 Additional Project Area. The Owner reserves the right to acquire and add property to the Project area subject to review and approval by the City Council. Upon such approval of the City, any such additional property to the Project will be subject to the terms of this Agreement. The Memorandum of Agreement, attached hereto as **Exhibit G**, will be modified to include such additional land. Notwithstanding the foregoing, the boundaries of the public improvement district are subject to change only in accordance with applicable state law.

ARTICLE IX **PUBLIC IMPROVEMENT DISTRICT**

Section 9.01 Public Improvement District. Concurrently with approval of this Agreement and per the Owner's request, the City will create a Public Improvement District (the "**PID**"), pursuant to Local Government Code, Chapter 372. The boundaries of the PID will correlate with the boundaries of the Property. The City expects to issue special revenue bonds secured by special assessments levied on the Property in the PID to help finance certain public improvements in the PID. Such public improvements and bond financing is more particularly described in the Service and Assessment Plan and the PID Financing Agreement for the PID.

ARTICLE X
AMENDMENTS TO THE AGREEMENT

Section 10.01 Amendments to Agreement.

- a. **Amendment Process.** This Agreement may be amended only by a written agreement signed by City and the Owner, as described in Section 10.01(b).
- b. **Major and Minor Amendments.** Due to the fact that the Project comprises a significant land area and its development will occur in phases over a number of years, Owner may request amendments to the Agreement and/or the Land Use Plan from time to time. “Major Amendments” shall be those that (i) increase the overall number of residential dwelling units by more than ten percent (10%) of the total units depicted on the Land Use Plan on a cumulative basis or by more than twenty percent (20%) within any one phase, or (ii) a change to the Land Use Plan that converts more than twenty percent (20%) of the overall land area in Pecan Woods, on a cumulative basis, to commercial and/or industrial use, understanding that in no circumstance shall any change to any land use exceed the adequacy of any public facility to service the any phase of the project, including the overall project as a whole, or (iii) elimination of a thoroughfare, or (iv) shifting of a thoroughfare by more than five-hundred (500) feet. Major Amendments to the Land Use Plan shall require approval by the City Council. “Minor Amendments” are all amendments that do not meet the definition of Major Amendments. Minor amendments shall be administratively approved by the City Manager (or his or her designee). If the City Manager and the Owner dispute the classification of an amendment as “major” or “minor”, the issue shall be referred to the City Council for final determination.
- c. **Vested Rights.** Amendments to this Agreement or the Land Use Plan shall not be considered a waiver of vested rights as described in Section 2.03.

ARTICLE XI
REPRESENTATIONS AND WARRANTIES

Section 11.01 Organization and Good Standing of Owner. Walton Texas is a Texas limited partnership, is duly organized and validly existing in good standing under the laws of the State of Texas, and has full power and authority to conduct its business as it is now being conducted, to own or use the properties and assets that it purports to own or use, and to perform all its obligations under this Agreement. Walton Pecan Woods and WPW are both Delaware limited partnerships, are duly organized and validly existing in good standing under the laws of the State of Delaware, are qualified and in good standing under the laws of the State of Texas, and have full power and authority to conduct their respective business as now being conducted, to own and use the properties and assets each purports to own or use, and to perform all of their respective obligations under this Agreement.

Section 11.02 Authority of Owner, No Conflict. This Agreement constitutes the legal, valid and binding obligation of Owner, enforceable against Owner in accordance with its terms. Owner has

the authority, and capacity to execute and deliver this Agreement and to perform its obligations under this Agreement.

Section 11.03 Organization and Good Standing of City. The City is a Texas home rule city and has full power and authority to conduct its business as it is now being conducted, to own or use the properties and assets that it purports to own or use, and to perform all its obligations under this Agreement.

Section 11.04 Authority of City; No Conflict. This Agreement constitutes the legal, valid and binding obligation of City, enforceable against City in accordance with its terms. City has the absolute and unrestricted right, power, authority, and capacity to execute and deliver this Agreement and to perform its obligations under this Agreement.

Section 11.05 Performance. Owner and City shall reasonably cooperate with one another to accomplish the intent and purpose of this Agreement, and will perform each and all of its duties and obligations pursuant to the Agreement.

Section 11.06 No Personal Liability of Public Officials. No public official or employee shall be personally responsible for any liability arising under or growing out of this Agreement.

ARTICLE XII

DEFAULT AND REMEDIES FOR DEFAULT

Section 12.01 Preventative Default Measures. In the event of a dispute involving an interpretation or any other aspect of this Agreement, upon Owner's request, the Director shall convene a meeting of the Parties as soon as reasonably practical and use all reasonable efforts to avoid processing delays and to resolve the dispute and carry out the spirit and purpose of this Agreement.

Section 12.02 Default. It shall be a default under this Agreement, if one of the Parties shall fail to perform any of its obligations under this Agreement and such failure shall remain uncured following the expiration of thirty (30) days after written notice of such failure. However, in the event the default is of a nature that cannot be reasonably cured within such thirty (30) day period, the defaulting party shall notify the other party within ten (10) days of receipt of the notice of the circumstances and the amount of time needed to cure the default. If the defaulting party provides this notice, the defaulting party shall have a longer period of time as may be reasonably necessary to cure the default in question.

Section 12.03 Default Unique to City. In addition, City shall be in default under this Agreement if Owner submits a complete application for a proposed development permit, utility service extension, or other development approval with respect to Pecan Woods that complies with the terms of this Agreement and the City Code, and, after reasonably adequate time for review and processing, the City staff unreasonably withholds the approval or release of the proposed development permit, utility service extension, or development approval that City staff is authorized to approve administratively. The failure or refusal of the City Council or any board or commission of City to approve a proposed development permit, utility service extension, or other development approval with respect to Pecan Woods that complies with the terms of this Agreement and the City

Code within a reasonable time after submission of a complete application shall constitute a default. The City shall also be in default if it imposes any requirements, standards, moratoria, or interim development controls upon Pecan Woods that are in conflict with the express provisions of this Agreement. The City shall not, however, be in default based upon the imposition of requirements, standards, moratoria, interim development controls or temporary moratoria that are required by a State or federal law, rule, regulation or administrative directive outside of City's control and influence, or authorized by state law, or due to an emergency constituting a threat to the public health or safety, provided that any such requirement, standard, or moratorium due to an emergency will continue with respect to Pecan Woods only during the duration of the emergency.

Section 12.04 Remedies Between City and Owner. Should any default between Owner and City remain uncured after Notice to the non-defaulting party, and after compliance with Section 12.07, then the non-defaulting party, whether Owner or City, may pursue any remedy that is available at law or in equity at the time of the breach (with the exception of damages), including code enforcement, mandamus, injunctive relief, and/or specific performance, provided, however, City may not seek to rescind or otherwise terminate this Agreement. City may withhold further processing or acceptance of applications from Owner that are related to the default by Owner until the default is cured or otherwise resolved. Neither party may seek monetary damages against the other party. The remedies listed in this paragraph are cumulative. If either City or the Owner should default in the performance of any obligations of this Agreement, the other party shall provide such defaulting party written notice of the default, and a minimum period of thirty (30) days to cure such default, prior to instituting an action for breach or pursuing any other remedy for default. City hereby waives any sovereign immunity from suit for such default specific to this Agreement.

Section 12.05 Remedies Between City and Third Parties. Should any default between a third party (that is, any individual or entity other than the Owner) and City remain uncured after Notice to the other as provided in Section 12.02, City may pursue the remedies listed in Section 12.04 against the third party, and the third party may pursue all remedies listed in Section 12.04 against City, except the City shall not be able to pursue the remedies of termination, rescission, or reverter, such remedies belonging exclusively to the Owner.

Section 12.06 No Liability For Actions of Others. Except as expressly set forth herein: (a) the liabilities, obligations and responsibilities of each owner, their successors and assigns, under this Agreement are several, and not joint; and (b) no owner, or successor or assign, of any portion of Pecan Woods will be in default under this Agreement or otherwise liable or responsible for any default which is not caused by such landowner or by any person acting by, through or under such owner or successor or assign.

Section 12.07 Mediation. If a dispute arises out of or relates to this Agreement or the breach thereof, the Parties shall first in good faith seek to resolve the dispute through negotiation between the upper management of each respective Party, such negotiations to occur within 15 days after one Party notifies the other Party of the dispute. If such dispute cannot be settled through negotiation, the Parties agree to try in good faith to settle the dispute by mediation before resorting to litigation, or some other dispute resolution procedure; provided that a Party may not invoke mediation unless it has provided the other Party with written notice of the dispute and has attempted in good faith to resolve such dispute through negotiation. All costs of negotiation, mediation, and arbitration collectively known as alternate dispute resolution ("ADR") shall be

assessed equally between the City and Owner with each party bearing their own costs for attorney's fees, experts, and other costs of ADR and any ensuing litigation. Mediation must be completed within 30 days after notification of the dispute.

ARTICLE XIII
MISCELLANEOUS PROVISIONS

Section 13.01 Effective Date. The Parties agree that the "Effective Date" of this Agreement shall be August 17, 2016.

Section 13.02 Termination. This Agreement may be terminated as to all of Pecan Woods only by express written agreement executed by City and either (i) Owner, or (ii) all the then current owners of all portions of Pecan Woods (other than owners of occupied single family, duplex, townhouse, or attached single family residential lots). This Agreement may be terminated as to a portion of Pecan Woods only by express written agreement executed by City and the owners of the portion of land affected by the termination; provided that if Owner still owns any portion of Pecan Woods, Owner must consent in writing to such termination. In the event this Agreement is terminated by mutual agreement of the Parties or by its terms, the Parties shall promptly execute and file of record in the Official Public Records of Hays County, Texas, a document confirming the termination of this Agreement in sufficient form to cause the release of the Memorandum of Agreement, and such other documents as may be appropriate to reflect the basis upon which such termination occurs.

Section 13.03 Agreement Binds Succession and Runs with the Land. This Agreement shall bind and inure to the benefit of the Parties, their successors and assigns. Subject to Section 13.05 below, the terms of this Agreement shall constitute covenants running with the land comprising Pecan Woods and shall be binding on all future owners of property in Pecan Woods. This Agreement will not be recorded, but a Memorandum of Agreement, in the form attached as **Exhibit G**, shall be recorded in the Official Public Records of Hays County, Texas. Nothing in this Agreement is intended to impose obligations on individual owners of platted lots, except as set forth in this Agreement.

Section 13.04 Assignment. Subject to Section 13.04(a) and (b) below, Owner may assign this Agreement with respect to all or part of Pecan Woods from time to time to any Party without the consent of the City. Owner shall provide the City thirty (30) days written notice of any such assignment. Upon such assignment or partial assignment, Owner shall be fully released from any and all obligations under this Agreement and shall have no further liability with respect to this Agreement for the part of Pecan Woods so assigned. The Agreement may only be assigned in the event that the Assignee agrees to perform without limitation each and every obligation assigned by Assignor (Owner) and any such assignment may only be made to an Assignee with the expertise and ability to carry out the obligations assigned.

- a. This Agreement shall run with the land. Any sale of a portion of Pecan Woods or assignment of any right hereunder shall not be deemed a sale or assignment to a Designated Successor or Assign unless the conveyance or transfer instrument effecting such sale or assignment expressly states that the sale or assignment is to a Designated Successor or Assign.

- b. Except as provided in the subpart (a) above, Owner and all future owners of all or any portion of Pecan Woods, including, without limitation, any affiliates of Owner to which all or any portion of the Property is conveyed or contributed, shall have the benefits of this Agreement, and the Property may be developed as set forth herein without notice or approval to the City provided, however, that this Agreement may be amended as set forth herein. In the case of nonperformance by one owner, the City may pursue all remedies against that nonperforming owner, but will not impede development activities of any performing owner as a result of that nonperformance unless and to the limited extent that such nonperformance pertains to a City requirement that also is necessary for the performing owner's project, in which event the performing owner may also pursue remedies against the nonperforming owner.

Section 13.05 Entire Agreement. This Agreement contains the entire agreement of the Parties. There are no other agreements or promises, oral or written, between the Parties regarding the subject matter of this Agreement except as set forth or identified herein. This Agreement can be amended only by written agreement signed by the Parties as provided for in this Agreement. This Agreement and the agreements between the Parties referenced in this Agreement, supersede all prior agreements between the Parties concerning the subject matter of this Agreement.

Section 13.06 Notice. It is contemplated that the Parties will frequently engage in informal communications with respect to the subject matter of this Agreement. However, any formal notices or other communications ("Notice") required to be given by one Party to another by this Agreement shall be given in writing addressed to the party to be notified at the address set forth below for such Party, (i) by delivering same in person, (ii) by depositing the same in the United States Mail, certified or registered, return receipt requested, postage prepaid, addressed to the party to be notified, or (iii) by depositing the same with Federal Express or another nationally recognized courier service guaranteeing "next day delivery", addressed to the party to be notified, or (iv) by sending same by email with confirming copy sent by one of the other methods described herein. Notice deposited in the United States mail in the manner described above shall be deemed effective from and after the earlier of the date of actual receipt or three (3) days after the date of such deposit. Notice given in any other manner shall be effective on the date delivered, if sent by confirmed email or personal delivery, or the day after deposit with a "next day delivery" service. For the purposes of notice, the addresses of the Parties shall, until changed as provided below, be as follows:

Owner: Walton Texas, LP
 c/o Walton Development & Management TX, LLC
 9811 South IH-35, Suite 4-200
 Austin, TX 78744
 Attention: Becky Collins
 T: (512) 347-7070
 E: becky.collins@walton.com

With copy to: Walton Development & Management TX, LLC
 5420 LBJ Freeway, Suite 790
 Dallas, Texas 75240

Attn: John Vick
T: (214) 838-2103
E: jvick@walton.com

With a copy to: Steven C. Metcalfe
Metcalfe Wolff Stuart & Williams, LLP
221 West 6th Street, Suite 1300
Austin, Texas 78701
T: (512) 404-2200
E: smetcalfe@mwswtexas.com

With a copy to: Walton Development and Management Inc. - DC
1650 Tysons Blvd., Suite 1500
Tysons, Virginia 22102
Attn: Wayne Souza, General Counsel
T: (703) 677-9068
E: wsouza@walton.com

With a copy to: Mayor
P.O. Box 40
100 Center Street
Kyle, Texas 78640
T: (512) 262-1010

With a copy to: City Attorney
P.O. Box 40
100 Center Street
Kyle, Texas 78640
T: (512) 262-1010

With a copy to: City Manager
P.O. Box 40
100 Center Street
Kyle, Texas 78640
T: (512) 262-1010
E: ssellers@cityofkyle.com

The Parties shall have the right at any time and from time to time to change their respective addresses, and each shall have the right to specify as its address any other address within the United States of America by at least five (5) days written notice to the other Party. If any date or any period provided in this Agreement ends on a Saturday, Sunday or legal holiday observed by banks in Hays County, Texas, the applicable period for calculating the notice shall be extended to the first business day following such Saturday, Sunday or legal holiday.

Section 13.07 Estoppel Certificate. Within ten (10) business days after receipt of a written request by Owner or a current owner of a tract in Pecan Woods, City will certify in a written instrument duly executed and acknowledged to any person, firm or corporation specified in such request as to (i) the validity and force and effect of this Agreement in accordance with its terms;

(ii) modifications or amendments (if any) to this Agreement and the substance of such modifications or amendments; (iii) the existence of any default to the best of City's knowledge; and (iv) such other factual matter that may be reasonably requested.

Section 13.08 No Joint Venture. It is acknowledged and agreed by the Parties that the terms of this Agreement are not intended to and shall not be deemed to create any partnership or joint venture among the Parties. City, its past, present and future officers, elected officials, employees and agents of City, do not assume any responsibilities or liabilities to any third party in connection with the development of Pecan Woods.

Section 13.09 Time. Time is of the essence of this Agreement. In computing the number of days for purposes of this Agreement, all days will be counted, including Saturdays, Sundays and legal holidays observed by banks in Hays County, Texas; however, if the final day of any time period falls on a Saturday, Sunday or legal holiday, then the final day will be deemed to be the next day that is not a Saturday, Sunday or legal holiday.

Section 13.10 Severability. If any provision of this Agreement is illegal, invalid, or unenforceable under present or future laws, then, and in that event, it is the intention of the parties that the remainder of this Agreement shall not be affected.

Section 13.11 Waiver. Any failure by one of the Parties to insist upon strict performance by the other Party of any material provision of this Agreement shall not be deemed a waiver of such provision or of any other provision of this Agreement, and such Party shall have the right at any time(s) thereafter to insist upon strict performance of any and all of the provisions of this Agreement.

Section 13.12 Applicable Law and Venue. THE CONSTRUCTION AND VALIDITY OF THIS AGREEMENT SHALL BE GOVERNED BY THE LAWS OF THE STATE OF TEXAS (WITHOUT REGARD TO CONFLICTS OF LAW PRINCIPLES). Venue for any dispute arising from or related to this Agreement shall be in a Texas state district court for Hays County as applicable, and shall be in accordance with the Texas Civil Practice and Remedies Code.

Section 13.13 Further Assurances. Both Parties agree that at any time after execution of this Agreement, they will, upon request of the other Party, execute and deliver such further documents and do such further acts and things as may be reasonably necessary or desirable to effectuate the terms of this Agreement.

Section 13.14 Incorporation of Exhibits and Other Documents by Reference. All Exhibits and other documents attached to or referred to in this Agreement are incorporated by reference for the purposes set forth in this Agreement.

Section 13.15 Counterparts. This Agreement may be executed in multiple counterparts which shall be construed together as a single original instrument as though all Parties had signed one instrument, and, when executed, each counterpart shall be binding upon and inure to the benefit of each of the Parties executing the instrument whether or not all other parties have executed same. Electronic or .pdf signatures of this Agreement shall be deemed original signatures and have the full force and affect as an original signature.

Section 13.16 Interpretation. Each of the Parties has been represented by counsel of their choosing in the negotiation and preparation of this Agreement. Regardless of which Party prepared the initial draft of this Agreement, this Agreement shall, in the event of any dispute, however its meaning or application, be interpreted fairly and reasonably and neither more strongly for or against any Party.

Section 13.17 Effect of Development Agreement. This Agreement, including all of the related Development Standards, approvals, consents and plans, shall remain in effect for the term of the Agreement regardless of whether all or any portion of Pecan Woods is annexed and/or zoned. To the extent this Development Agreement or the Development Standards conflict with the City Code, this Development Agreement and the Development Standards shall control.

Section 13.18 No Waiver of Governmental Immunity; Governmental Function. The Owner acknowledges and agrees that the City is a governmental entity engaging in a governmental function. By entering into this Agreement the City does not waive its governmental immunity or the limitations as to damages contained in any applicable statutes.

Section 13.19 Independent Contractors. It is expressly understood and agreed by all Parties hereto that in performing their services hereunder, the Owner or its subcontractors or tenants at no time will be acting as agents of the City and that all consultants or contractors engaged by the Owner, its subcontractors or tenants will be independent contractors. The Parties hereto understand and agree that the City will not be liable for any claims that may be asserted by any third party occurring in connection with services performed by the Owner under this Agreement, unless any such claims are due to the fault of the City.

Section 13.20 Recitals. The recitals to this Agreement are incorporated herein as findings of fact.

Section 13.21 Exhibits.

- Exhibit A: Property Description
- Exhibit A-1: Jurisdiction Map
- Exhibit B: Land Use Plan
- Exhibit B-1: Phasing Plan
- Exhibit C: Site Development Regulations
- Exhibit D: Development Waivers
- Exhibit E: Parks, Trails and Open Space Plan
- Exhibit E-1: Description of Parks, Trails and Open Space
- Exhibit E-2: Parkland Phasing
- Exhibit E-3: Park Maintenance Building
- Exhibit F: Typical Cross Sections
- Exhibit G: Memorandum of Agreement
- Exhibit H: Utility Exhibit

THE CITY OF KYLE, TEXAS

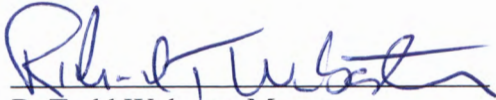

R. Todd Webster, Mayor

STATE OF TEXAS §
 §
COUNTY OF Hays §

BEFORE ME, the undersigned Notary Public in and for the State of Texas, on this day personally appeared Richard Todd Webster, Mayor of the City of Kyle, and acknowledged that he is fully authorized to execute the foregoing document and that he executed such document for the purposes and consideration therein expressed and in the capacity therein stated.

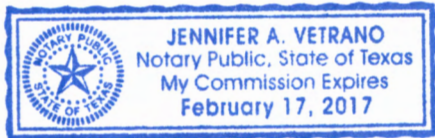
GIVE UNDER MY HAND AND SEAL OF OFFICE this 24th day of August,
2016.

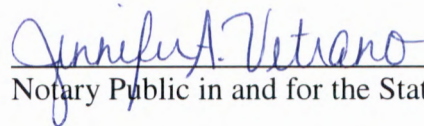

Notary Public in and for the State of Texas

WALTON TEXAS, LP,
a Texas limited partnership

By: Walton Texas GP, LLC,
a Texas limited liability company,
its General Partner

By: Walton International Group, Inc.,
a Nevada corporation,
its Manager

By: John Vick
Name: John Vick
Title: Authorized Signatory

STATE OF TEXAS §
 §
COUNTY OF Tarrant §

BEFORE ME, the undersigned Notary Public in and for the State of Texas, on this day personally appeared John Vick, an Authorized Signatory of Walton International Group, Inc., a Nevada corporation, Manager of Walton Texas GP, LLC, a Texas limited liability company, General Partner of Walton Texas, LP, a Texas limited partnership, on behalf of said limited partnership, in the capacity herein stated.

GIVE UNDER MY HAND AND SEAL OF OFFICE this 19th day of August, 2016.

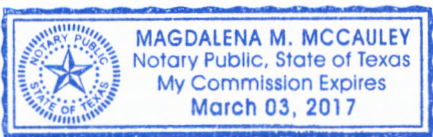

Magdalena M. McCauley
Notary Public in and for the State of Texas

WALTON PECAN WOODS, LP,
a Delaware limited partnership

By: WPW GP, LLC,
a Delaware limited liability company,
its General Partner

By: Walton Land Management (USA), Inc.,
a Delaware corporation,
its Manager

By: John Vick
Name: John Vick
Title: Authorized Signatory

STATE OF TEXAS §
 §
COUNTY OF Tarrant §

BEFORE ME, the undersigned Notary Public in and for the State of Texas, on this day personally appeared John Vick, an Authorized Signatory of Walton Land Management (USA), Inc., a Delaware corporation, Manager of WPW GP, LLC, a Delaware limited liability company, General Partner of Walton Pecan Woods, LP, a Delaware limited partnership, on behalf of said limited partnership, in the capacity herein stated.

GIVE UNDER MY HAND AND SEAL OF OFFICE this 19th day of August, 2016

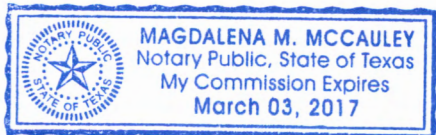

Magdalena M. McCauley
Notary Public in and for the State of Texas

WPW DEVELOPMENT SUB, LP,
a Delaware limited partnership

By: Walton Pecan Woods Development GP, LLC,
a Delaware limited liability company,
its General Partner

By: Walton Pecan Woods Development, LP,
a Delaware limited partnership,
its Manager

By: WPW GP, LLC,
a Delaware limited liability company,
its General Partner

By: Walton Land Management (USA), Inc.,
a Delaware corporation,
its Manager

By: John Vick
Name: John Vick
Title: Authorized Signatory

STATE OF TEXAS §
 §
COUNTY OF Tarrant §

BEFORE ME, the undersigned Notary Public in and for the State of Texas, on this day personally appeared John Vick, an Authorized Signatory of Walton Land Management (USA), Inc., a Delaware corporation, Manager of WPW GP, LLC, a Delaware limited liability company, General Partner of Walton Pecan Woods Development, LP, a Delaware limited partnership, Manager of Walton Pecan Woods Development GP, LLC, a Delaware limited liability company, General Partner of WPW Development Sub, LP, a Delaware limited partnership, on behalf of said limited partnership, in the capacity herein stated.

GIVE UNDER MY HAND AND SEAL OF OFFICE this 19th day of August, 2016.

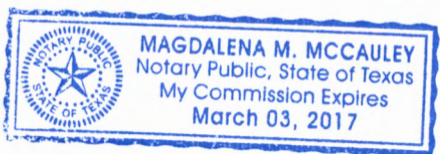

Magdalena M. McCauley
Notary Public in and for the State of Texas

**EXHIBIT A-1
JURISDICTION MAP**

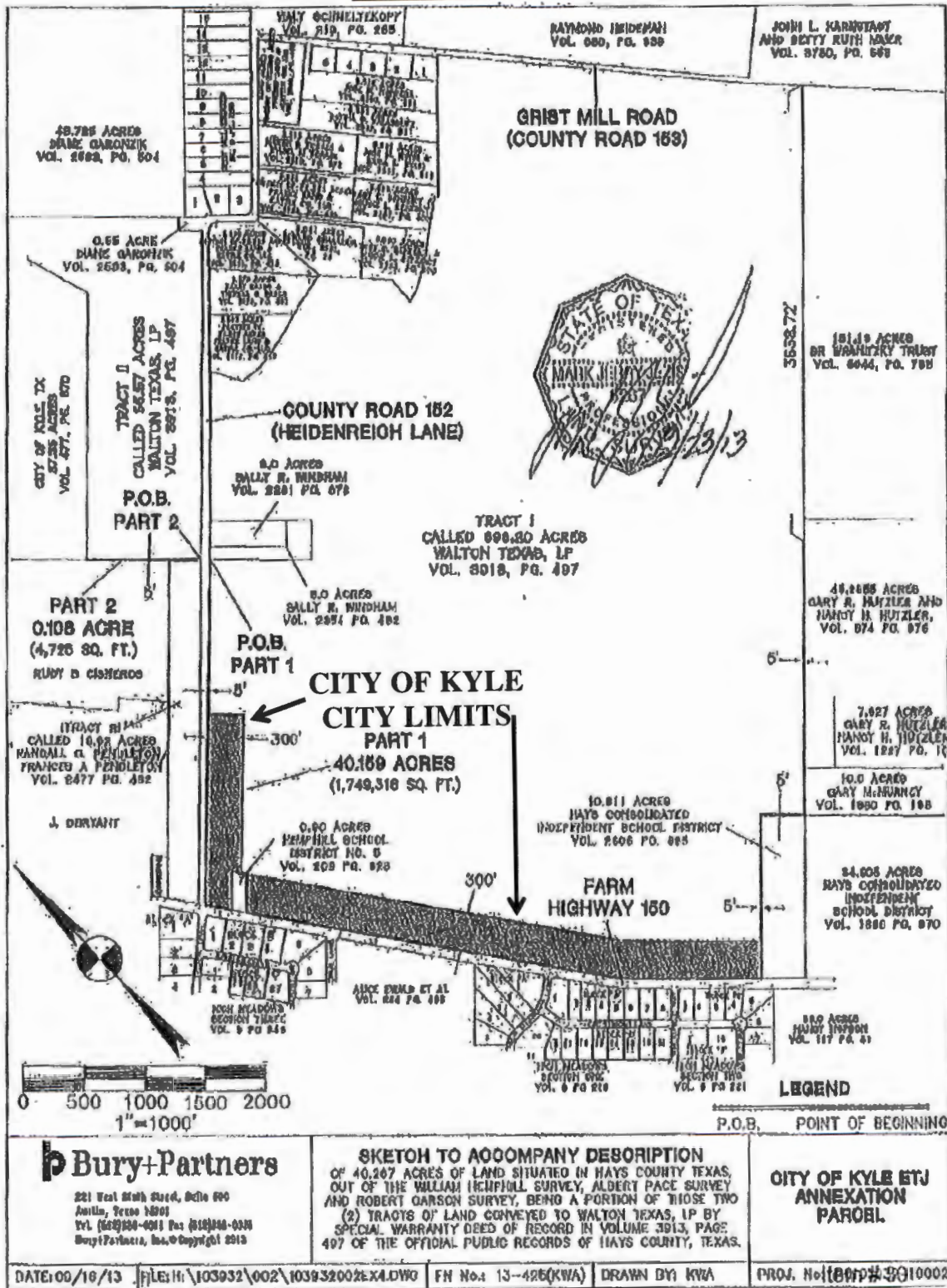

Bury+Partners

221 West Ninth Street, Suite 400
Austin, Texas 78701
Tel: (512) 248-0911 Fax: (512) 248-0338
Bury+Partners, Inc. © Copyright 2015

SKETCH TO ACCOMPANY DESCRIPTION
OF 40.267 ACRES OF LAND SITUATED IN HAYS COUNTY TEXAS,
OUT OF THE WILLIAM HECHMILL SURVEY, ALBERT PACE SURVEY
AND ROBERT GARSON SURVEY, BEING A PORTION OF THOSE TWO
(2) TRACTS OF LAND CONVEYED TO WALTON TEXAS, LP BY
SPECIAL WARRANTY DEED OF RECORD IN VOLUME 3913, PAGE
497 OF THE OFFICIAL PUBLIC RECORDS OF HAYS COUNTY, TEXAS.

**CITY OF KYLE ETJ
ANNEXATION
PARCEL**

**EXHIBIT B
LAND USE PLAN**

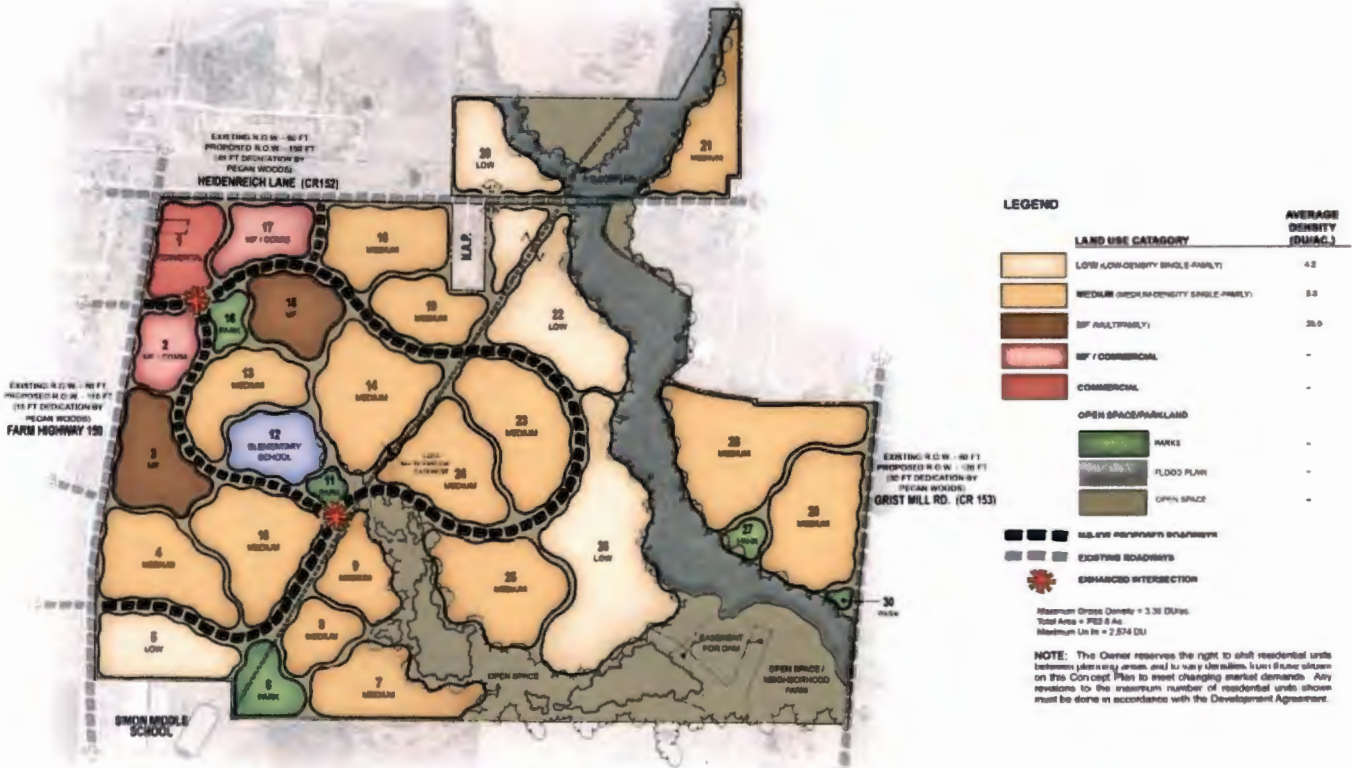

**EXHIBIT B-1
PHASING PLAN**

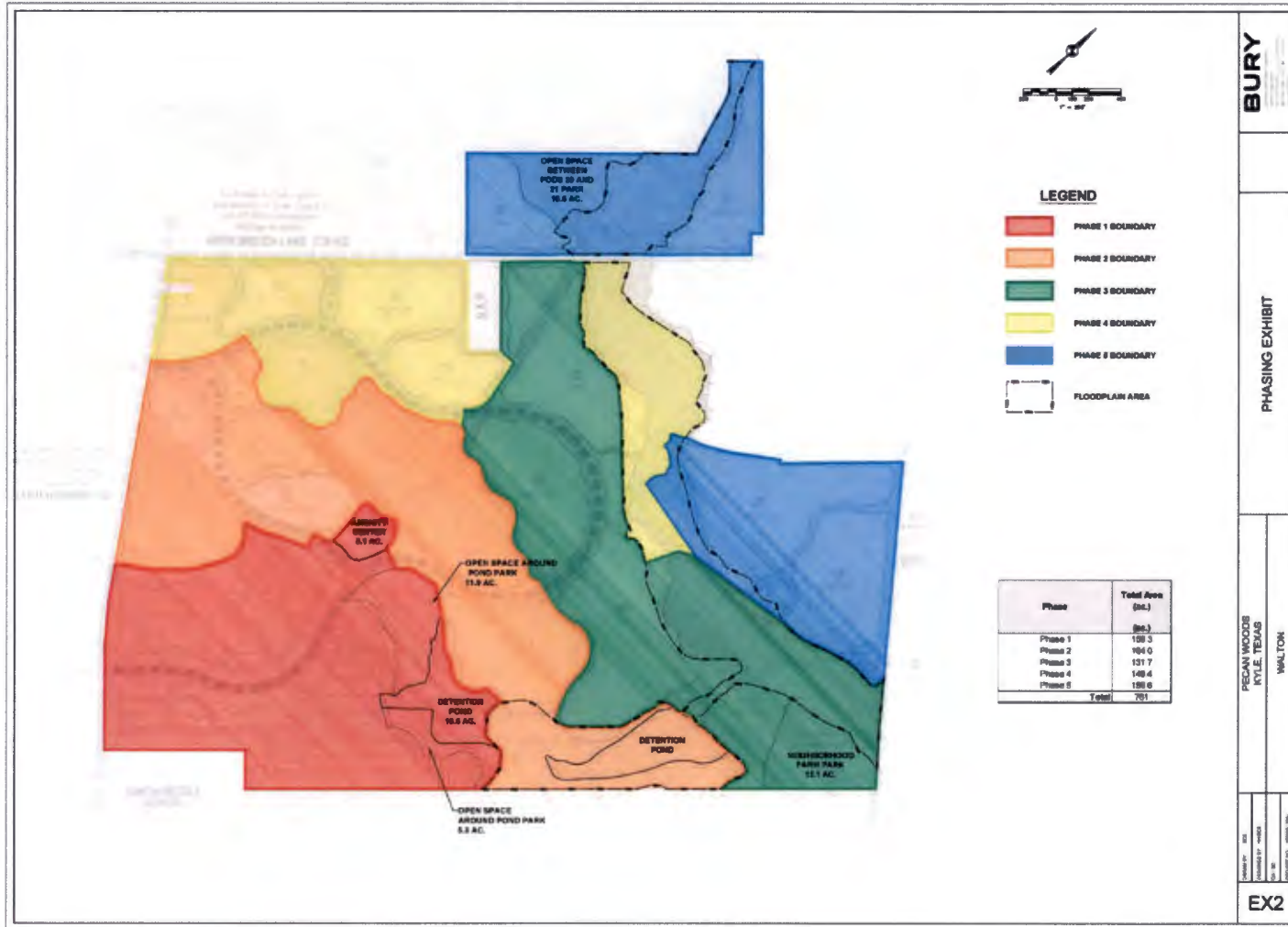

EXHIBIT C
SITE DEVELOPMENT REGULATIONS

Residential Uses

Standard Category	Single Family		Multi-family		Unit Size, Minimum (Sq. Ft.)	Lot/Parcel Area, Minimum (Sq. Ft.)	Density, Maximum (Units per Net Acre) ²	Front Yard Setback, Main Structure Minimum (Feet) ³	Minimum Attached Garage Front Setback (Feet) ³	Minimum Attached Garage Front Setback, Side-Facing(Feet) ^{3,6}	Interior Side Yard Setback, Minimum (Feet)	Street Side Yard Setback, Minimum (Feet)	Rear Yard Setback, Minimum to Home (Feet) ⁷	Rear Yard Setback, Minimum to Garage (Feet) ⁷	Lot Width, Minimum (Feet) ⁸	Impervious Coverage, Maximum % ⁵	Building Height, (Feet)	Minimum Units	Maximum Units
	Low	Medium	MF																
R-1-1 ¹	2200	8190	3.9	25 ⁹	30	15	7 ¹⁰	15 ¹⁰	10	5	70	60%	35	0	315				
R-1-2 ¹	1900	6825	4.7	20 ⁹	25	15	5 ¹⁰	10 ^{4,10}	10	5	60	60%	35	359	439				
R-1-A (a) ¹	1600	5000	4.5	15 ⁹	20	N/A	5 OR 10 & 0 ^{10,11}	10 ^{4,10}	10	5	50	65%	35	1112	1436				
R-1-A (b) ^{1,19}	1000	4000	6.2	15 ⁹	20	N/A	5 OR 10 & 0 ^{10,11}	10 ^{4,10}	10	5	40	65%	35	0	200				
R-1-T ¹	1000	2500	10.0	15 ⁹	20	N/A	0	10 ^{4,10}	10	5	25	80%	35	0	200				
R-1-C	500	9000	36.0	25	N/A	N/A	N/A	15	15	N/A	80	60%	45	0	315				
R-2	900	9000	6.0	25 ¹³	N/A	N/A	5	10	15	N/A	70	60%	35	0	315				
R-3-1	850	12	12.0	25	N/A	N/A	15 ¹⁷	15	15 ¹⁷	N/A	80	70%	35 ¹⁵	0	315				
R-3-2	400	12	21.0	25	N/A	N/A	15 ¹⁸	15	15 ¹⁸	N/A	80	70%	45 ¹⁶	0	315				
R-3-3	500	14	28.0	25	N/A	N/A	15 ¹⁸	15	15 ¹⁸	N/A	90	80%	45 ¹⁶	1188	1452				

Notes: Indicates deviations from Setbacks and Zoning Ordinance #568, Chart 1, May 5, 2009, and from Chart 2 (Maximum Lot Coverage).
"Low", "Medium" and "MF" divisions relate to land use designations on the Pecan Woods Concept Land Use Plan
Footnotes: (See next page)

- Footnotes**
1. All Single Family zones, other than R-1-C (condominium) and R-2 (duplex) shall contain only one dwelling unit per lot.
 2. Net Area, for the purpose of calculating residential density, is the gross area of the Planning Area, less public road dedications for Collector and higher street classifications and easements for major transmission utilities (water, electric, and gas).
See illustrations for examples of garage locations, configurations and setbacks. Front setbacks to main structure may increase from minimum to vary building line along residential streets.
 3.

A. Front-loaded (standard)	F. Front-loaded (rear)
B. Side-loaded (standard)	G. Alley-loaded (attached)
C. Side-loaded (alternative)	H. Alley-loaded (detached)
D. Side-loaded corner (attached)	I. 3-Car Split (standard)
E. Side-loaded corner (detached)	J. 3-Car Split (alternative)
 4. Street Side Yard setback may be reduced to 5 feet when side lot line is adjacent to an alley.
 5. Impervious Coverage Maximum is total roofed area of main building, any accessory building(s), and any flatwork.
 6. Side entry garages that are not located on a corner lot may only occur on lots with a width greater than or equal to 60 feet.
Rear setback is to the main structure of the house. The rear setback for an alley-facing and/or detached garage is 5 feet (see sketch E, F, G, H, and Q, dimensions 7 and 8)
 7. Minimum Lot Width is measured at the Front Building Setback Line.
 9. Covered, open-sided porches may encroach a maximum of 6 feet into the Front Yard Setback.
 10. Pop-outs may encroach up to 2 feet into required side yards.
 11. Side yard setback for the R-1-A zone may be either 5 feet on each side, or 10 feet on one side and 0 feet on the other in a zero-lot-line configuration. Zero-lot-line lot means a single-family lot that has a side wall along or near one of the lot lines so that a usable yard of a minimum of ten feet from the side lot line to the building line is created on the other side of the lot. In no case shall any part of the structure, with the exception of roof eaves, be constructed so as to encroach upon or over the vertical extension of a lot line.
 12. Minimum lot area for property in the R-3-1 and R-3-2 districts is 12,000 square feet, plus an additional 1,500 square feet for each dwelling unit in excess of four units; provided that the density limitations set forth for each district shall apply.
 13. Front setbacks may vary from 20 feet to 30 feet, as long as the *average* front setback for the Planning Area is 25 feet.
 14. Minimum lot area for property in the R-3-3 district is 12,000 square feet, plus an additional 1,500 square feet for each residential unit.
 15. Not to exceed two stories.
 16. Not to exceed three stories.
 17. For R-3-1 adjacent to any Single Family zone, the setback from the common property line to multifamily residential structures shall be per Sketches R and S. Trash facilities must be located at least 50 feet from the common property line.
 18. For R-3-2 and R-3-2 adjacent to any Single Family zone, the setback from the common property line to multifamily residential structures shall be per Sketches R and S. Trash facilities must be located at least 50 feet from the common property line.
 19. For R-1-A(a) lots (40 feet in width) shall be an alley-loaded product, unless the Planning Director approves an alternative product.

SKETCHES FOR SITE DEVELOPMENT REGULATIONS

Multifamily and Commercial

Sheet 3

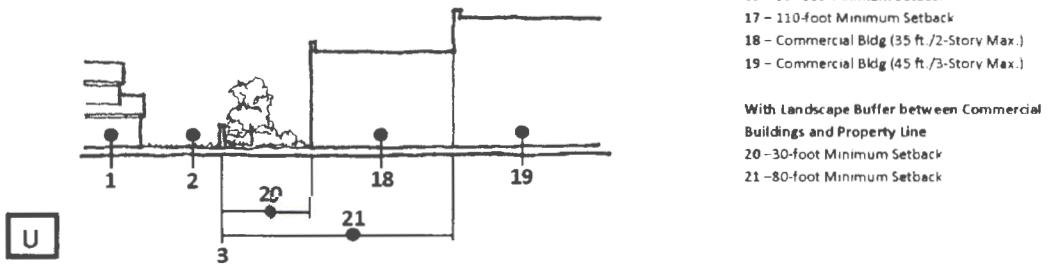
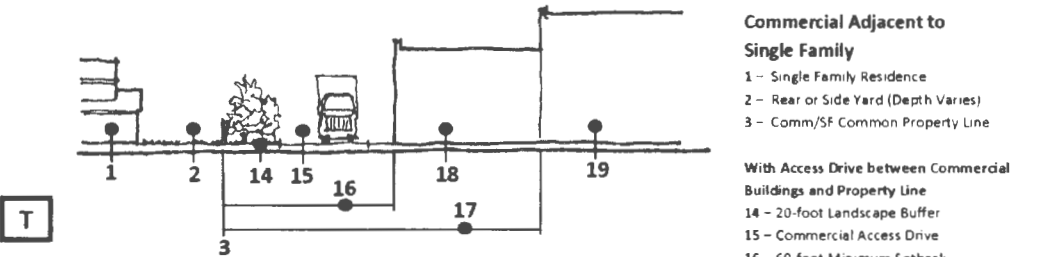
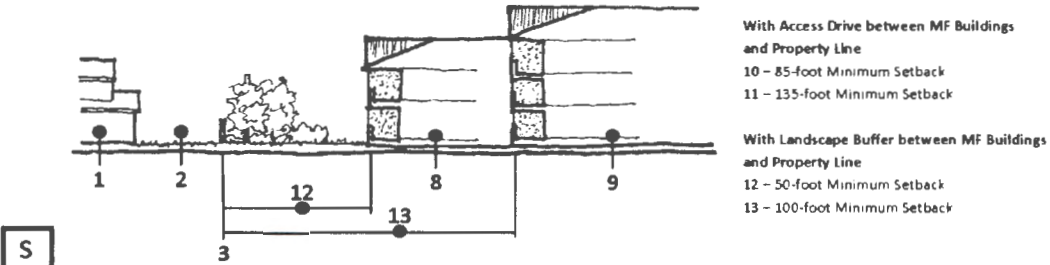
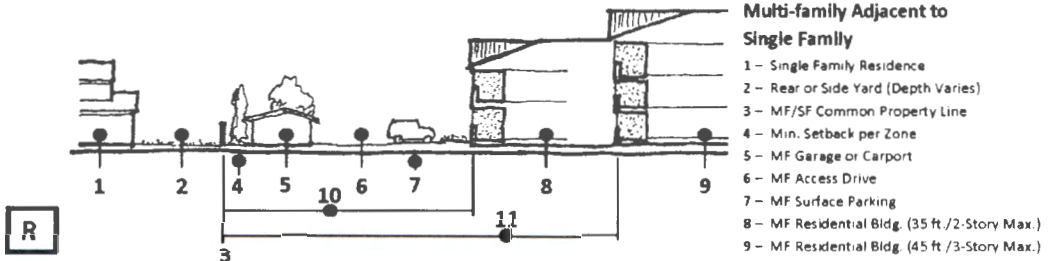

SKETCHES FOR SITE DEVELOPMENT REGULATIONS

Garage Configurations and Typical Setback Dimensions and Locations

Sheet 1

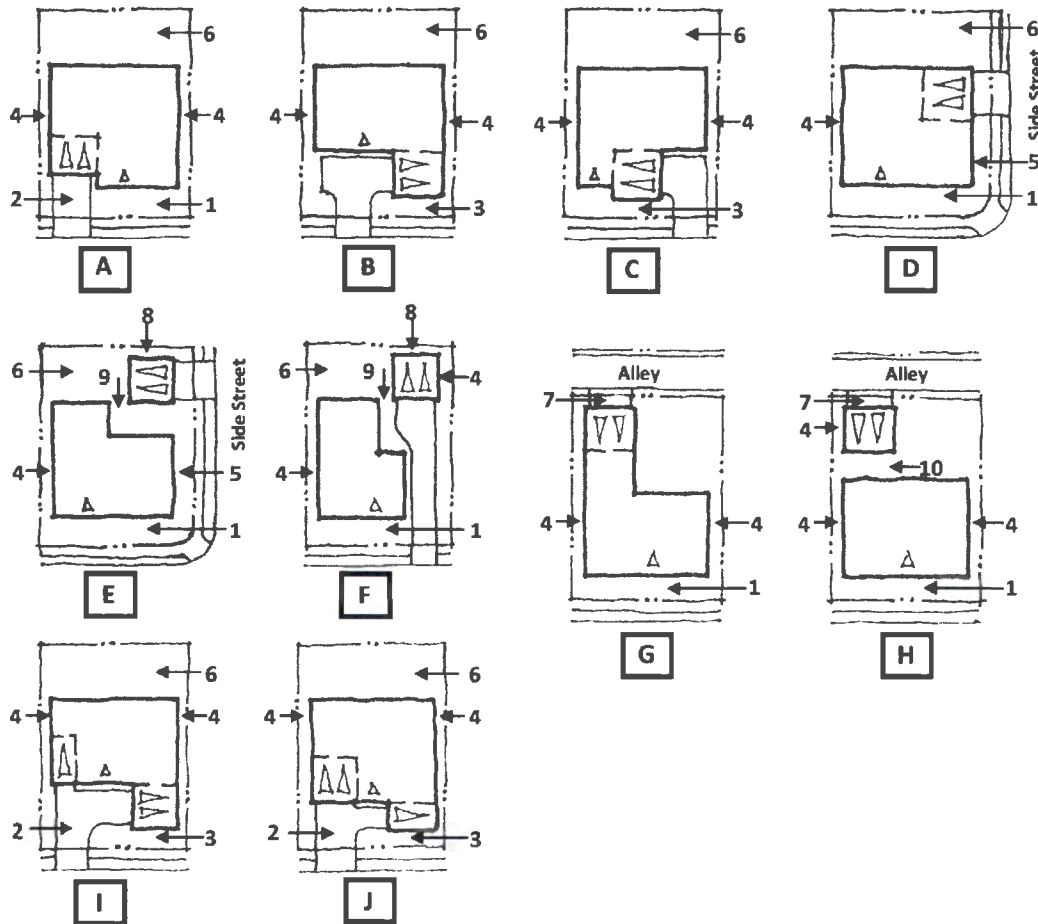

- Garage Configurations**
 (Examples for illustration purposes;
 other configurations are allowed)
- A – Front-loaded (standard)
 - B – Side-loaded (standard)
 - C – Side-loaded (alternative)
 - D – Side-loaded corner (attached)
 - E – Side-loaded corner (detached)
 - F – Front-loaded (back of lot)
 - G – Alley-loaded (attached)
 - H – Alley-loaded (detached)
 - I – 3-car split (standard)
 - J – 3-car split (alternative)

Dimensions (minimums, ft.)

	R-1-1	R-1-2	R-1-A	R-1-T	
1	25	20	15	15	Front Setback to Main Structure
2	30	25	20	20	Front Setback to Front-Facing Garage
3	15	15	N/A	N/A	Front Setback to Side-Entry Garage
4	7	5	5 or 0	0	Interior Side Setback
5	15	10	10	10	Street Side Setback
6	10	10	10	10	Rear Setback
7	5	5	5	5	Rear Setback to Alley-Facing Garage
8	5	5	5	5	Rear Setback to Garage Wall
9	10	10	10	10	Separation between Buildings
10	15	15	15	15	Separation between Buildings

SKETCHES FOR SITE DEVELOPMENT REGULATIONS

Lot Types, Impervious Cover, and Typical Setback Dimensions

Sheet 2

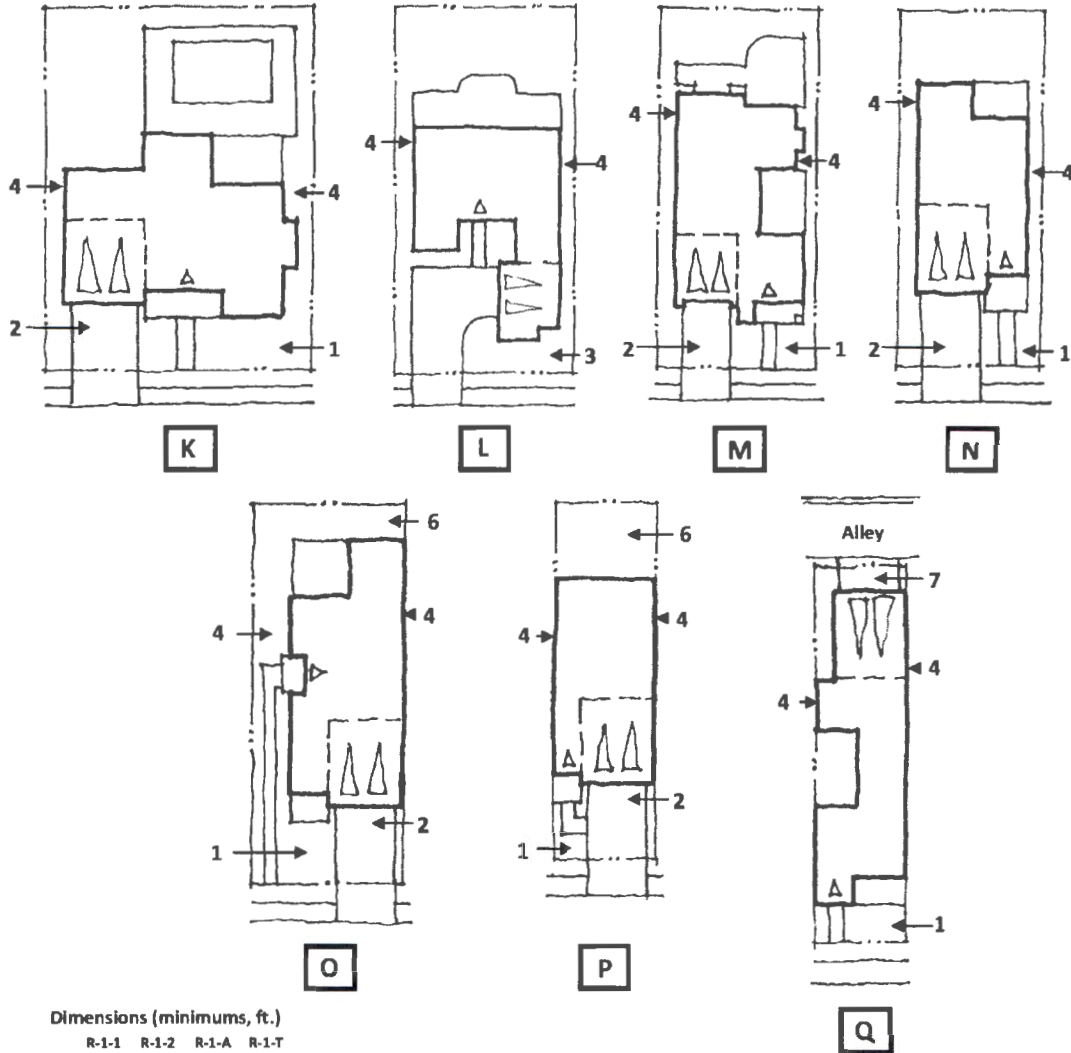

Dimensions (minimums, ft.)

	R-1-1	R-1-2	R-1-A	R-1-T	
1	25	20	15	15	Front Setback to Main Structure
2	30	25	20	20	Front Setback to Front-Facing Garage
3	15	15	N/A	N/A	Front Setback to Side-Entry Garage
4	7	5	5 or 10 & 0	0	Interior Side Setback
5	15	10	10	10	Street Side Setback
6	10	10	10	10	Rear Setback
7	5	5	5	5	Rear Setback to Alley-Facing Garage
8	5	5	5	5	Rear Setback to Garage Wall
9	10	10	10	10	Separation between Buildings
10	15	15	15	15	Separation between Buildings

Lot Types

(Examples for illustration purposes; other lot sizes are allowed)
 K - 70' x 120' lot, R-1-1
 L - 60' x 120' lot, R-1-2
 M - 50' x 115' lot, R-1-A
 N - 40' x 100' lot, equal side yards, R-1-A
 O - 40' x 100' lot, zero lot line, R-1-A
 P - 27' x 95' lot, front-loaded, R-1-T
 Q - 25' x 100' lot, alley-loaded, R-1-T

**EXHIBIT C
SITE DEVELOPMENT REGULATIONS**

Commercial Uses

Standard Category		Unit Size, Min Sq. Ft.	Lot/Parcel Area, Minimum Sq. Ft.	Units per Acre, Maximum/Gross Acre	Front Yard Setback, Min Feet	Side Setback, Minimum Feet, Interior	Street Side Yard Setback, Min Feet	Rear Yard Setback, Minimum Feet	Lot Width, Min Feet	Impervious Cover, Max. %, Main Bldg	Building Height, Maximum (Feet or Stories)
NC ¹	Comm'l	N/A	N/A	N/A	20	5 ²	15	20 ²	50	N/A	2 Stories
CC ¹		N/A	N/A	N/A	25	15 ³	15	25 ³	80	N/A	3 stories

Note: Open off-street parking and loading areas will not be considered as lot coverage under this subsection.
 "Comm'l" division relates to Commercial land use designations on the Pecan Woods Concept Land Use Plan.

Footnotes:

1. Setbacks for the NC and CC districts, when adjacent to single family residential, shall be 50 feet with no structures (other than carports or one-story garages), limited to 2 stories in height from 50 feet to 100 feet, and may be 3 stories (for the CC district) beyond 100 feet.
2. For NC adjacent to any Single Family zone, the setback from the common property line to commercial structures shall be per Sketches T and U. Trash facilities must be located a minimum of 50 feet from the common property line.
3. For CC adjacent to any Single Family zone, the setback from the common property line to commercial structures shall be per Sketches T and U. Trash facilities must be located a minimum of 50 feet from the common property line.

EXHIBIT D
DEVELOPMENT WAIVERS

CODE REFERENCE	PROPOSED ACTION
General Requirements SEC. 41-134	
(a)-(1) <i>Conformity With Comprehensive Plan</i>	Proposed Action: Modify Section to allow deviation from comprehensive plan. When a conflict occurs, the Development Agreement prevails.
(a)-(2) <i>Connecting Streets</i>	Proposed Action: Review on case by case basis during platting
(a)-(4) <i>Inspection of Construction</i>	Proposed Action: Clarify the authority to conduct inspection within the ETJ
(c)	City will pay incremental difference of inspection costs between our need and theirs for oversized projects initiated by the City. Refer to section 5.02 (b) "Offsite Infrastructure" for additional information.
SEC. 41-136.	
(a) <i>Area Requirements</i>	Proposed Action: Add flexibility to modify minimum lot size requirements and zoning requirements
SEC. 41-137.	
(a) <i>Layout</i>	Proposed Action: Allow flexibility to deviate from the comprehensive plan.
(e) <i>Curvilinear Streets</i>	Proposed Action: Add minimum curve radius requirements for residential lane. Min. radius to be 180'. For curve radii less than 275' a maximum speed limit of 25 m.p.h. will be required.
(g)(4) <i>Street intersection radii</i>	Proposed Action: Modify minimum return requirements at alleys to be 15' in lieu of 25'
(k)(1) <i>Pavement and R.O.W width – Minimum standards</i>	Proposed Action: Modify R.O.W width for Residential Lane to be 50 feet. Modify R.O.W width for collectors to "varies", but greater than 60 feet for entry roads. Provide median improvements in accordance to Utility Street Section detail STR-4.
(k)(2)(b) <i>Pavement and R.O.W width – Entry Road Sections</i>	Proposed Action: Modify the requirement to match entry road cross section provided (STR-4)
m(4) <i>Street Grades</i>	Proposed Action: Modify speed requirements to be 35 mph for collectors, 25 mph for local and residential lane
<i>Addition</i>	Proposed Action: Add a provision that will allow knuckles
<i>Addition</i>	Proposed Action: 50 feet minimum Tangent requirements
(k)(1)	Utility assignment to be per details provided.

CODE REFERENCE	PROPOSED ACTION
SEC. 41-140.	
(a) Watershed Protection	<p>Proposed Action: The following water quality measures will be provided:</p> <p>During Construction (Temporary BMP's)</p> <ul style="list-style-type: none"> • Silt Fence • Rock Berms • Sediment Traps • Curb Inlet Protection • Stabilized Construction Entrances • Mulch Tubing <p>After Construction (Permanent BMP's)</p> <ul style="list-style-type: none"> • Grassy Swales • Vegetative Filter Strips • Storm Drain Outfall Protection that includes rock riprap to armor the existing discharge channel • Level Spreaders to dissipate concentrated outfalls to maximize the effectiveness of the grassy swales and vegetative filter strips <p>Details for the above BMP's are provided at the end of this exhibit</p>
SEC. 41-141.	
(d) Easements abutting Streets	<p>Proposed Action: With the exception of easements containing transformer pads, the PUE requirements are modified to be 5 feet in lieu of 15 feet for individual utility assignments. Refer to Exhibit F "Typical Cross Sections" for typical easement locations and utility assignments.</p>
SEC 41-142	
(a) Water mains	<p>Proposed Action: Dependent on approval of the financial district, acceleration of storage, pump station, and transmission line improvements may be constructed if necessary.</p>
(b) Sewer mains	<p>Proposed Action: Dependent on approval of the financial district, acceleration of a new wastewater treatment plant or expansion the existing wastewater treatment plant may be constructed if necessary.</p>
SEC. 41-143.	
(a) Sidewalks	<p>Proposed Action: Provide connectivity between sidewalks. Construct Hike and Bike Trails and connectivity between trails, and sidewalks per Plum Creek Trail Plan, and Parks, Trails and Open Space plan.</p>
SEC. 41-146.	
(a), (c) Streetlights	<p>Proposed Action: The development shall provide street lighting at all intersections, and for turnarounds of cul-de-sacs greater than 200 feet.</p>
SEC. 41-147.	
(c) Parkland Dedication	<p>Proposed Action: Provide Parkland dedication in excess of the minimum requirement. See Parkland Exhibit for breakdown.</p>
SEC. 50-407	<p>Proposed Action: The Home Owners Association (HOA) will be</p>

CODE REFERENCE	PROPOSED ACTION
	responsible for maintaining any watercourses and associated structures on the property. For any watercourse or associated structures located within a drainage easement dedicated to the City of Kyle, maintenance responsibility shall be that of the City of Kyle.
SEC. 50-410	
(g)(4)	Proposed Action: Temporary ESCs to be installed prior to the Preconstruction Meeting.
SEC. 50-412	Proposed Action: Maintenance Plan must be file prior to Final Acceptance
SEC. 50-413	Proposed Action: Low Impact Development (LID) features will be incorporated where practical. Potential LID features are encouraged not required.
SEC. 50-414	
(a)(4)	Proposed Action: This applies to industrial use only.
SEC. 50-417	Proposed Action: Enforcement will be tied to each NOI, and each phase will have its own NOI.
SEC. 50-418	Proposed Action: Specifically regarding repeat violations. If the issuance of a violation occurs, the violation will be issued for the specific phase in which the violation occurred according to the TPDES Construction General Permit (CGP) TXR150000 and SWP3. Each phase permitted under a separate TPDES CGP will be regulated separately; therefore, a repeat violation would only be applicable if the same violation occurred within the same phase based on that phase's TPDES CGP and SWP3.
SEC. 50 ORDINANCE 891 APPENDIX A	Proposed Action: The LID Ordinance will not apply.
LANDSCAPE	Proposed Action: The development will provide landscape within easements, open spaces, along roadways, natural waterways, and entry road.
STREET PARKING	Proposed Action: Street parking will be provided along collector roads in accordance with Utility and Street Section Details provided.
BIKE LANE	Proposed Action: Bike lane will be provided along collector roads in accordance with Utility and Street Section Details.
SCHOOL	Proposed Action: Dedicate land for elementary school.
FIRST RESPONDER	Proposed Action: Dedicate one to two acres of land for first responder facilities.
AMENITY CENTER	Proposed Action: Provide an amenity center for the development.

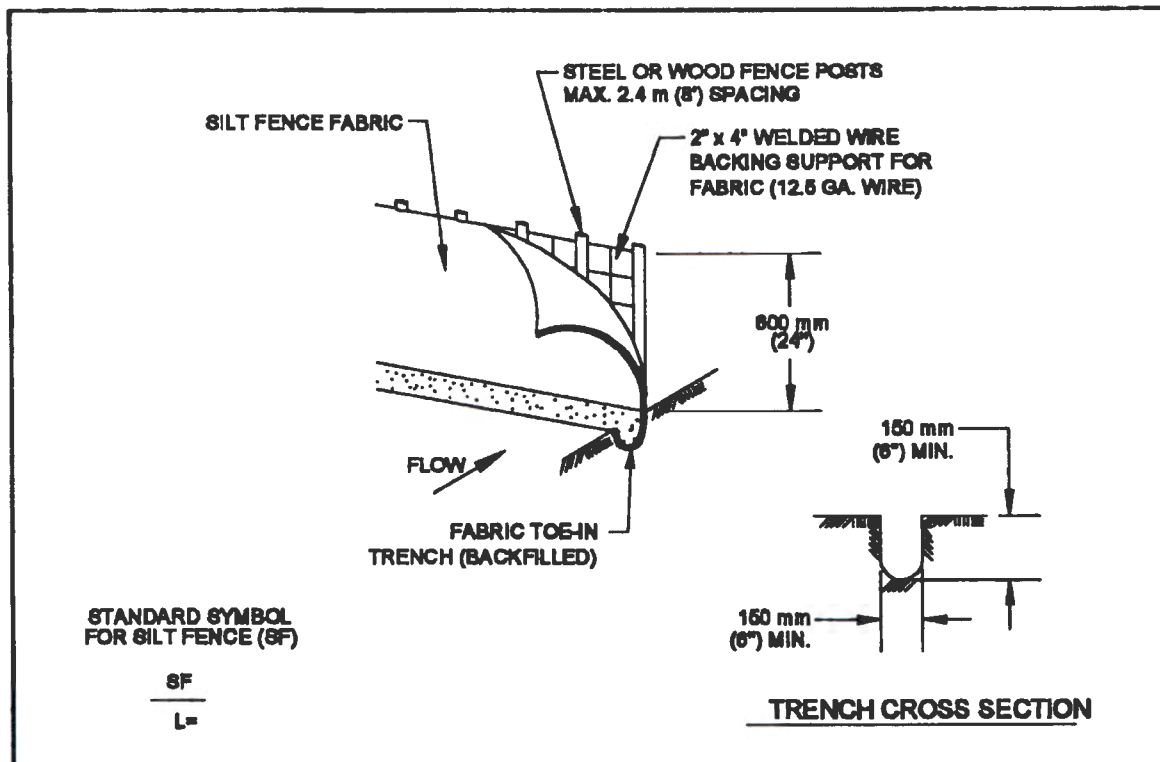

1. STEEL OR WOOD POSTS WHICH SUPPORT THE SILT FENCE SHALL BE INSTALLED ON A SLIGHT ANGLE TOWARD THE ANTICIPATED RUNOFF SOURCE. POST MUST BE EMBEDDED A MINIMUM OF 300 mm (12 INCHES). IF WOOD POSTS CANNOT ACHIEVE 300 mm (12 inches) DEPTH, USE STEEL POSTS.
2. THE TOE OF THE SILT FENCE SHALL BE TRENCHED IN WITH A SPADE OR MECHANICAL TRENCHER, SO THAT THE DOWNSLOPE FACE OF THE TRENCH IS FLAT AND PERPENDICULAR TO THE LINE OF FLOW.
3. THE TRENCH MUST BE A MINIMUM OF 150 mm (6 inches) DEEP AND 150 mm (6 inches) WIDE TO ALLOW FOR THE SILT FENCE FABRIC TO BE LAID IN THE GROUND AND BACKFILLED WITH COMPACTED MATERIAL.
4. SILT FENCE FABRIC SHOULD BE SECURELY FASTENED TO EACH STEEL OR WOOD SUPPORT POST OR TO WOVEN WIRE, WHICH IS IN TURN ATTACHED TO THE STEEL OR WOOD FENCE POST.
5. INSPECTION SHALL BE MADE WEEKLY OR AFTER EACH RAINFALL EVENT AND REPAIR OR REPLACEMENT SHALL BE MADE PROMPTLY AS NEEDED.
6. SILT FENCE SHALL BE REMOVED WHEN THE SITE IS COMPLETELY STABILIZED SO AS NOT TO BLOCK OR IMPEDE STORM FLOW OR DRAINAGE.
7. ACCUMULATED SILT SHALL BE REMOVED WHEN IT REACHES A DEPTH OF 150 mm (6 inches). THE SILT SHALL BE DISPOSED OF ON AN APPROVED SITE AND IN SUCH A MANNER THAT WILL NOT CONTRIBUTE TO ADDITIONAL SILTATION.

<p>CITY OF AUSTIN WATERSHED PROTECTION DEPARTMENT</p>	<p>SILT FENCE</p>	
<p><i>Greg S. Rapp</i> 9/1/2011 ADOPTED</p>	<p>THE ARCHITECT/ENGINEER ASSUMES RESPONSIBILITY FOR APPROPRIATE USE OF THIS STANDARD.</p>	<p>STANDARD NO. 642S-1</p>

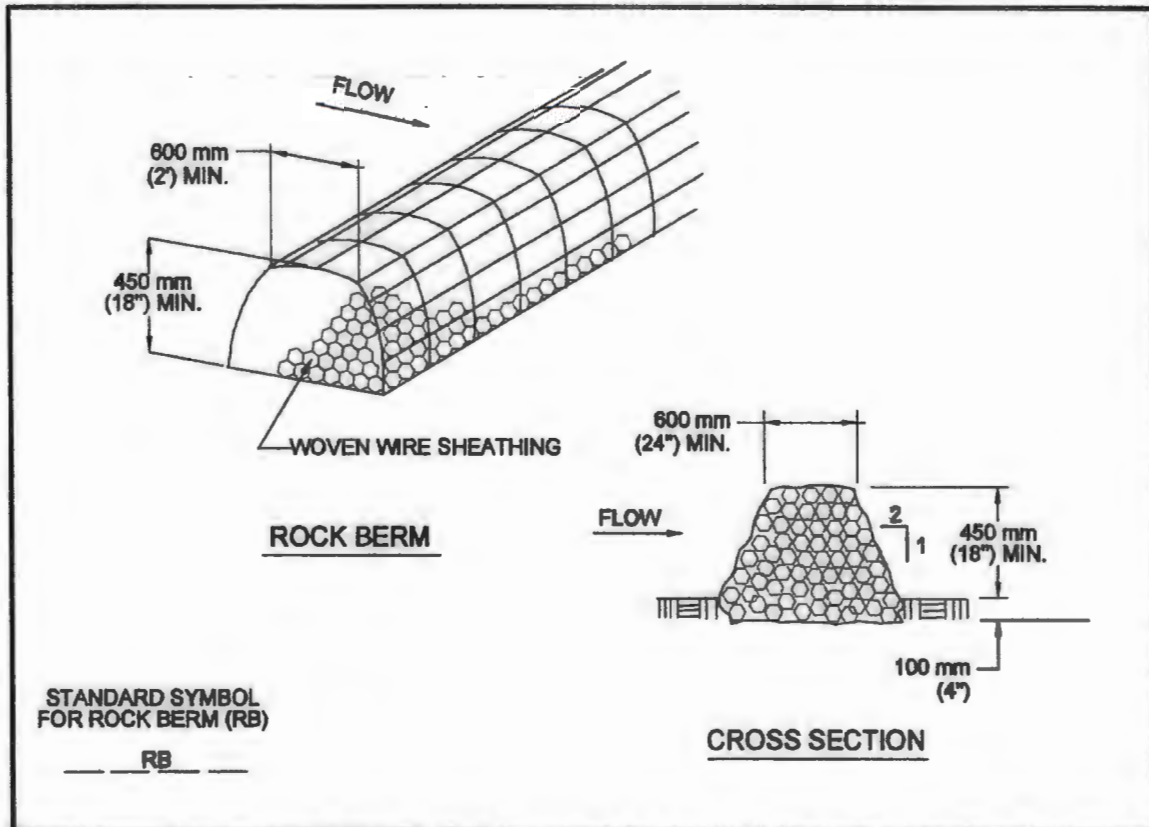

NOTES:

1. USE ONLY OPEN GRADED ROCK 75 to 125 mm (3 to 5") DIAMETER FOR ALL CONDITIONS.
2. THE ROCK BERM SHALL BE SECURED WITH A WOVEN WIRE SHEATHING HAVING MAXIMUM 25 mm (1") OPENING AND MINIMUM WIRE DIAMETER OF 12.9 mm (20 GAUGE).
3. THE ROCK BERM SHALL BE INSPECTED DAILY OR AFTER EACH RAIN, AND THE STONE AND/OR FABRIC CORE-WOVEN SHEATHING SHALL BE REPLACED WHEN THE STRUCTURE CEASES TO FUNCTION AS INTENDED, DUE TO SEDIMENT ACCUMULATION AMONG THE ROCKS, WASHOUT, CONSTRUCTION TRAFFIC DAMAGE, ETC.
4. IF SEDIMENT REACHES A DEPTH EQUAL TO ONE-THIRD THE HEIGHT OF THE BERM OR 150 mm (6"), WHICHEVER IS LESS, THE SEDIMENT SHALL BE REMOVED AND DISPOSED OF ON AN APPROVED SITE AND IN A MANNER THAT WILL NOT CREATE A SEDIMENTATION PROBLEM.
5. WHEN THE SITE IS COMPLETELY STABILIZED, THE BERM AND ACCUMULATED SEDIMENT SHALL BE REMOVED AND DISPOSED OF IN AN APPROVED MANNER.

<p>CITY OF AUSTIN WATERSHED PROTECTION DEPARTMENT</p>	<p>ROCK BERM</p>	<p>STANDARD NO. 639S-1</p>
<p><i>Theresa S. Ryan P.E.</i> 8/24/2010 ADOPTED</p>	<p>THE ARCHITECT/ENGINEER ASSUMES RESPONSIBILITY FOR APPROPRIATE USE OF THIS STANDARD.</p>	

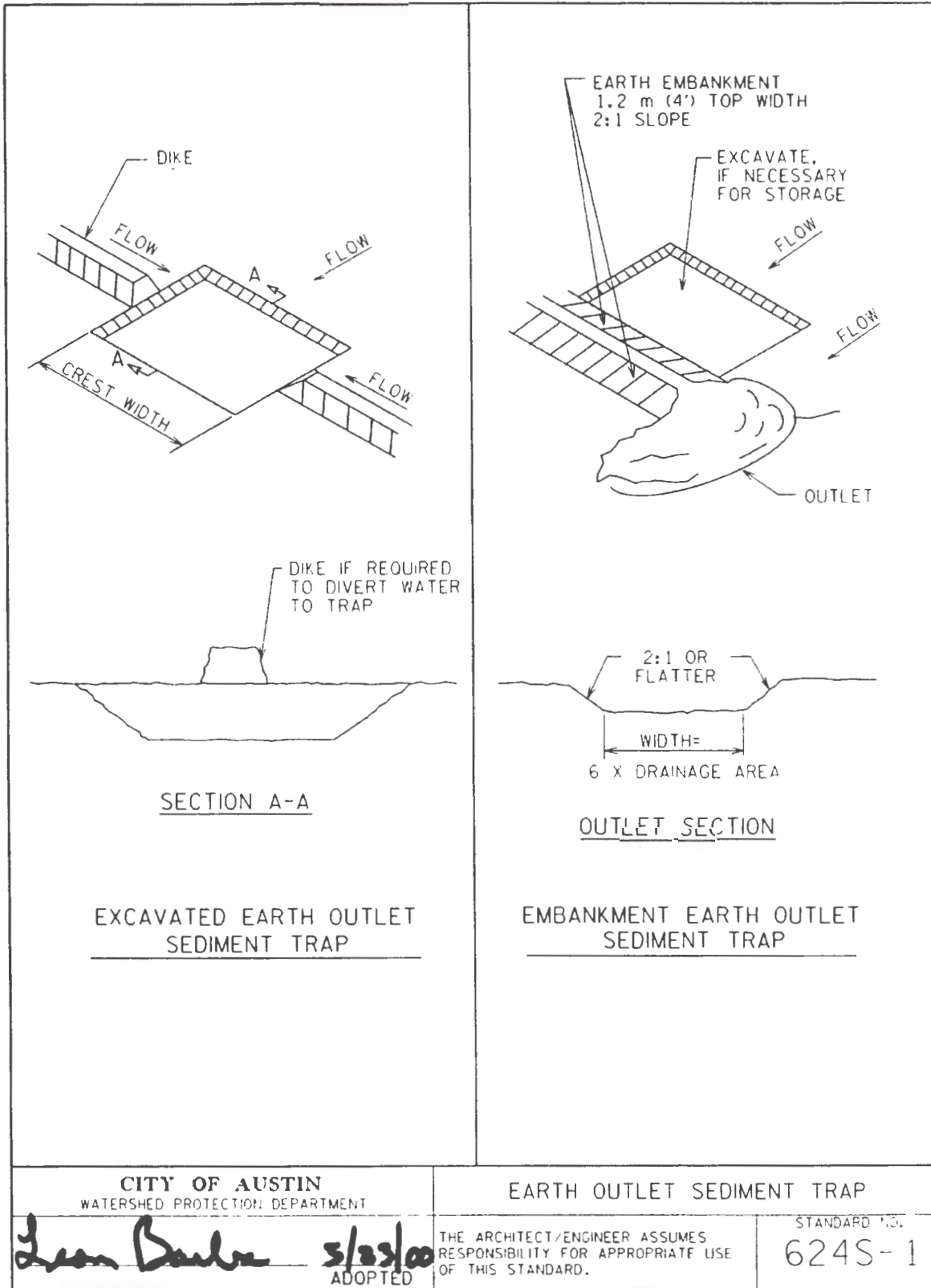

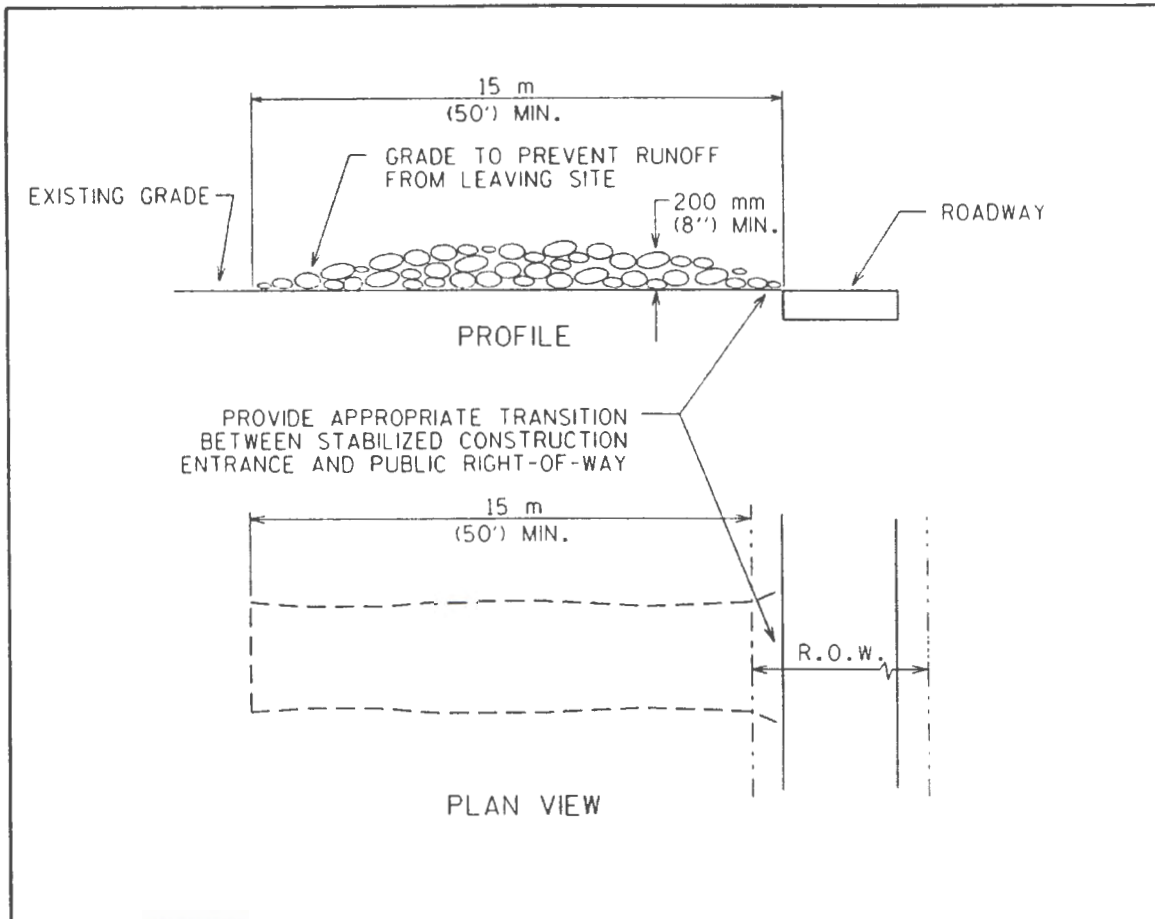

NOTES:

1. STONE SIZE: 75-125 mm (3-5'') OPEN GRADED ROCK.
2. LENGTH: AS EFFECTIVE BUT NOT LESS THAN 15 m (50').
3. THICKNESS: NOT LESS THAN 200 mm (8'').
4. WIDTH: NOT LESS THAN FULL WIDTH OF ALL POINTS OF INGRESS/EGRESS.
5. WASHING: WHEN NECESSARY, VEHICLE WHEELS SHALL BE CLEANED TO REMOVE SEDIMENT PRIOR TO ENTRANCE ONTO PUBLIC ROADWAY. WHEN WASHING IS REQUIRED, IT SHALL BE DONE ON AN AREA STABILIZED WITH CRUSHED STONE AND DRAINS INTO AN APPROVED TRAP OR SEDIMENT BASIN. ALL SEDIMENT SHALL BE PREVENTED FROM ENTERING ANY STORM DRAIN, DITCH OR WATERCOURSE USING APPROVED METHODS.
6. MAINTENANCE: THE ENTRANCE SHALL BE MAINTAINED IN A CONDITION THAT WILL PREVENT TRACKING OR FLOWING OF SEDIMENT ONTO PUBLIC ROADWAY. THIS MAY REQUIRE PERIODIC TOP DRESSING WITH ADDITIONAL STONE AS CONDITIONS DEMAND, AS WELL AS REPAIR AND CLEAN OUT OF ANY MEASURE DEVICES USED TO TRAP SEDIMENT. ALL SEDIMENTS THAT IS SPILLED, DROPPED, WASHED OR TRACKED ONTO PUBLIC ROADWAY MUST BE REMOVED IMMEDIATELY.
7. DRAINAGE: ENTRANCE MUST BE PROPERLY GRADED OR INCORPORATE A DRAINAGE SWALE TO PREVENT RUNOFF FROM LEAVING THE CONSTRUCTION SITE.

<p>CITY OF AUSTIN WATERSHED PROTECTION DEPARTMENT</p>	<p>STABILIZED CONSTRUCTION ENTRANCE</p>
<p><i>Leon Baula</i> 5/23/16 ADOPTED</p>	<p>THE ARCHITECT/ENGINEER ASSUMES RESPONSIBILITY FOR APPROPRIATE USE OF THIS STANDARD.</p> <p>STANDARD NO. 641S-1</p>

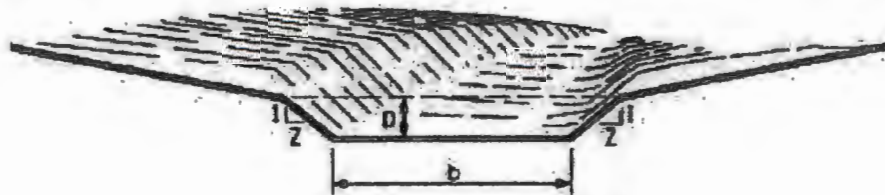

TRAPEZOIDAL CROSS SECTION

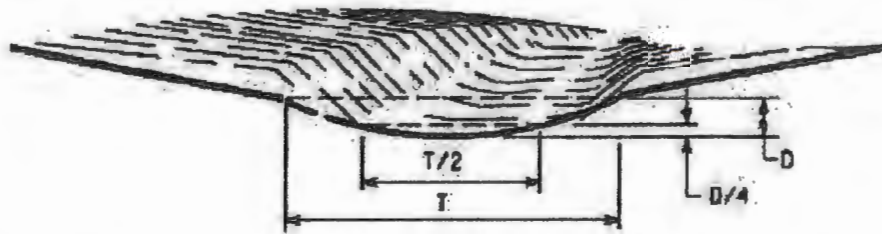

PARABOLIC CROSS SECTION

STANDARD SYMBOL

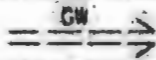

GENERAL NOTES:

1. EXCEPT AS INDICATED ON THE DRAWINGS OR DIRECTED BY THE ENGINEER OR DESIGNATED REPRESENTATIVE, ALL TREES, BRUSH, STUMPS, OBSTRUCTIONS AND OTHER OBJECTIONABLE MATERIAL SHALL BE REMOVED AND DISPOSED OF SO AS NOT TO INTERFERE WITH THE PROPER FUNCTIONING OF THE WATERWAY.
2. THE WATERWAY SHALL BE EXCAVATED OR SHAPED TO LINE, GRADE, TYPICAL SECTIONS AND CROSS-SECTION INDICATED ON THE DRAWINGS AND SHALL BE FREE OF BANK PROJECTIONS OR OTHER IRREGULARITIES, WHICH COULD IMPEDE NORMAL FLOW.
3. FILL SHALL CONFORM TO STANDARD SPECIFICATION ITEM NO. 132S, "EMBANKMENT".
4. EARTHEN CHANNELS SHALL ALWAYS BE STABILIZED WITH THE APPROPRIATE SOIL RETENTION BLANKET WHICH SHALL CONFORM TO STANDARD SPECIFICATION ITEM NO. 605S, "SOIL RETENTION BLANKET".

<p>CITY OF AUSTIN WATERSHED PROTECTION DEPARTMENT</p>	<p>GRASS LINED SWALE</p>	
<p><i>W. A. [Signature]</i> 10/27/09 ADOPTED</p>	<p>THE ARCHITECT/ENGINEER ASSUMES RESPONSIBILITY FOR APPROPRIATE USE OF THIS STANDARD.</p>	<p>STANDARD NO. 627S-1</p>

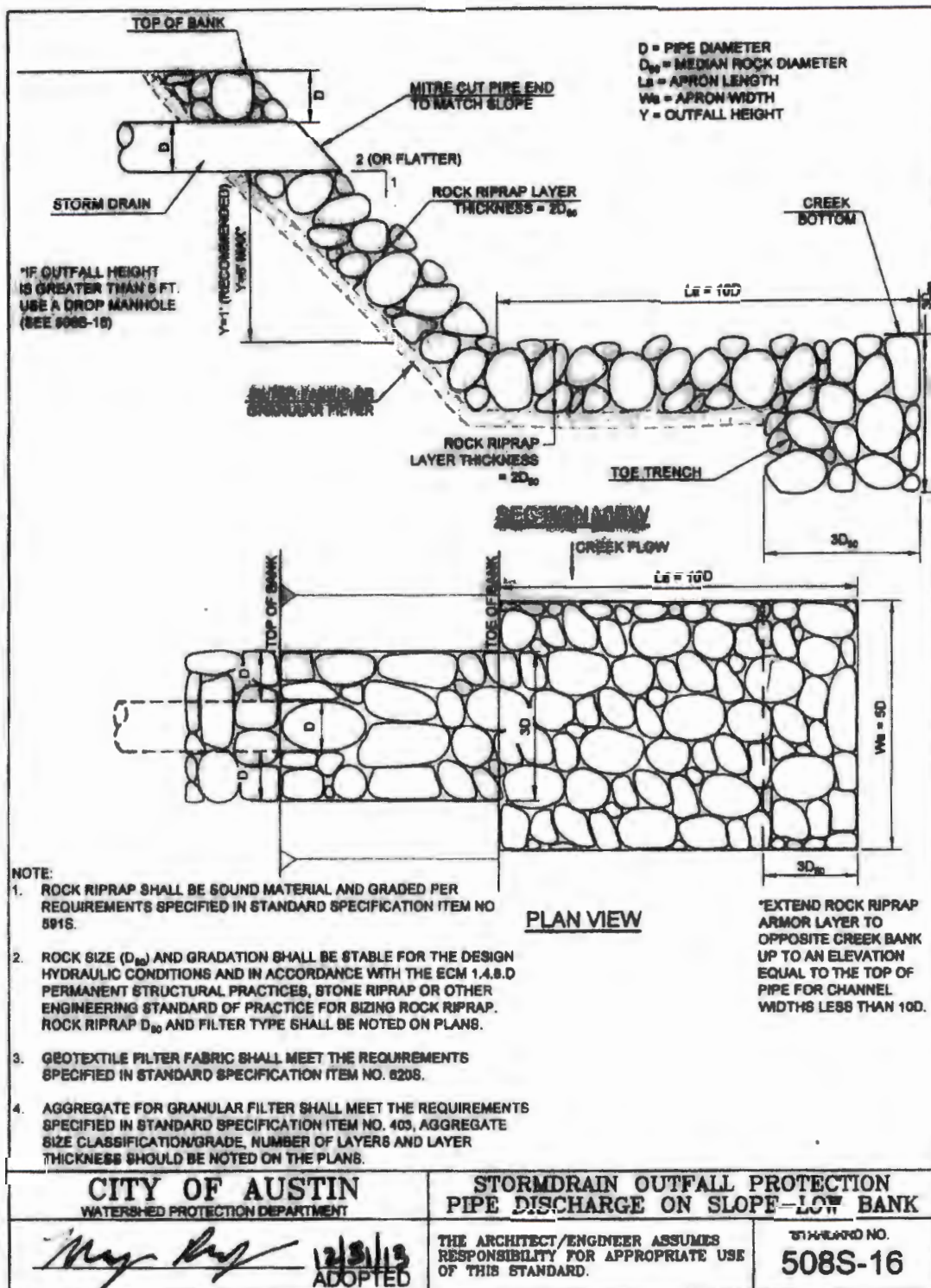

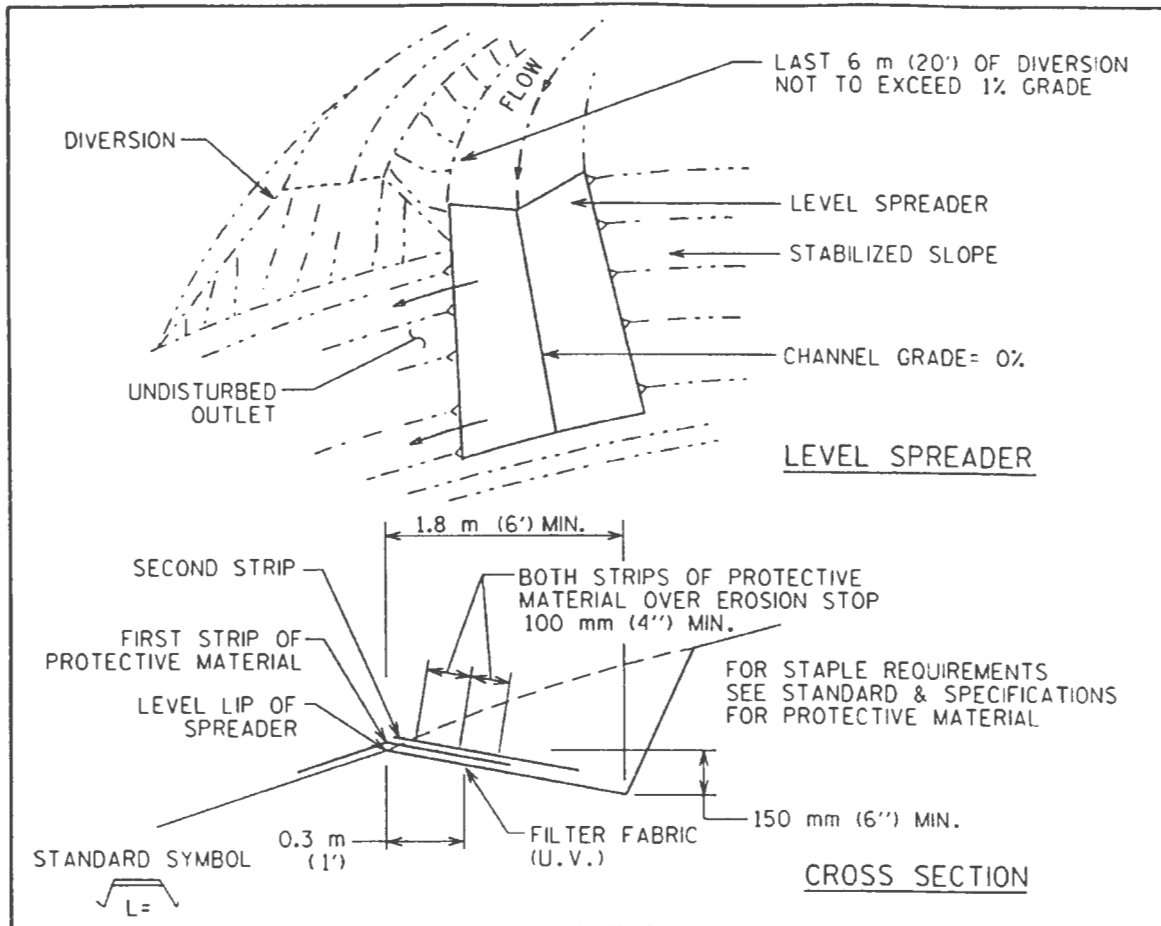

GENERAL NOTES:

1. LEVEL SPREADERS SHALL BE INSTALLED UNDER THE DIRECT SUPERVISION OF THE ENGINEER.
2. CONSTRUCT LEVEL LIP ON ZERO PERCENT GRADE TO INSURE UNIFORM SPREADING OF SEDIMENT-FREE RUNOFF (CONVERTING CHANNEL FLOW TO SHEET FLOW).
3. LEVEL SPREADER SHALL BE CONSTRUCTED ON UNDISTURBED SOIL (NOT ON FILL).
4. A MATTING EROSION STOP SHALL BE PLACED VERTICALLY AND AT LEAST 150 mm (6'') DEEP IN A SILT TRENCH 0.3 m (1') BACK OF AND PARALLEL WITH THE LIP. THIS EROSION STOP SHALL EXTEND THE ENTIRE LENGTH OF THE LEVEL LIP AND SHALL BE TRIMMED AFTER BACKFILLING WITH TAMPED SOIL, SO THAT THE UPPER EDGE IS FLUSH WITH THE SOIL SURFACE.
5. THE ENTIRE LEVEL LIP AREA SHALL BE PROTECTED BY PLACING 2 STRIPS OF JUTE, EXCELSIOR OR OTHER APPROVED PROTECTIVE MATERIAL AS SHOWN ABOVE.
6. THE ENTRANCE CHANNEL SHALL NOT EXCEED A 1% GRADE FOR AT LEAST 6 m (20') BEFORE ENTERING SPREADER.
7. STORM RUNOFF CONVERTED TO SHEET FLOW SHALL OUTLET ONTO STABILIZED AREAS. WATER SHALL NOT BE RECONCENTRATED IMMEDIATELY BELOW THE POINT OF DISCHARGE.
8. PERIODIC INSPECTION AND REQUIRED MAINTENANCE SHALL BE PROVIDED.

<p>CITY OF AUSTIN WATERSHED PROTECTION DEPARTMENT</p>	<p>LEVEL SPREADER</p>
<p><i>J. P. N. 44</i> 3-27-00 ADOPTED</p>	<p>THE ARCHITECT/ENGINEER ASSUMES RESPONSIBILITY FOR APPROPRIATE USE OF THIS STANDARD.</p> <p style="text-align: right;">STANDARD NO. 634S-1</p>

EXHIBIT E
PARKS, TRAILS AND OPEN SPACE PLAN

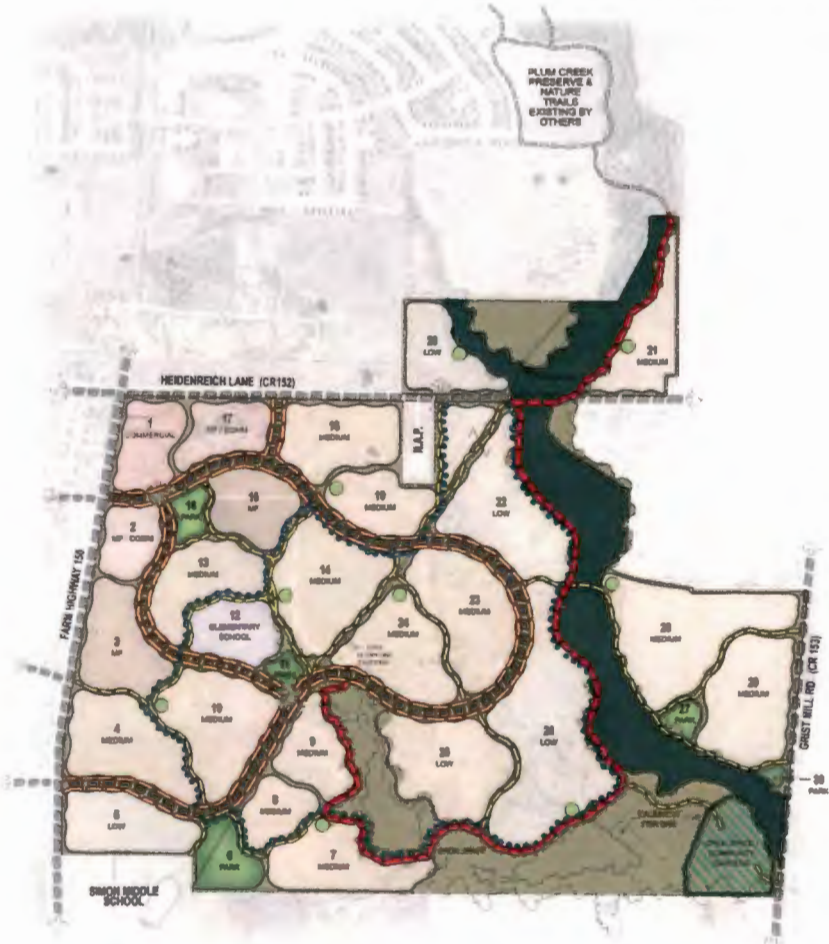

Park Description	Area Dedicated as Parkland (sq.)
Floodplain	130.0
Detention Pond outside FP	10.0
Open Space Around Detention Pond	17.2
Open Space Between Pads 20 & 21 Park	10.0
Neighborhood Farm Park	13.1
Parkland Hike and Bike Trails	2.4
Total Parkland Dedication	182.3
Required (2.884 LUE x 78 LUE)	41.3

Based on 2.5 miles of Concrete Hike and Bike Trails to be dedicated to parkland. Of this area, 1.8 miles of trail is located on the floodplain, while 0.6 miles is located in Open Space (Note: an additional 3.4 miles of trail located in Open Space/Neighborhood is proposed, but is not to be dedicated as parkland).

NOTE: A PORTION OF NEIGHBORHOOD PARKING MAY BE USED AS ACTIVE OR PASSIVE RECREATION AREA OR CHANGING STRUCTURED VEHICLES THROUGHOUT THE COURSE OF THE PROJECT. THESE AREAS SHALL BE PROVIDED AS NEIGHBORHOOD PARKING. NEIGHBORHOOD PARKING SHALL BE PROVIDED AS NEIGHBORHOOD PARKING. NEIGHBORHOOD PARKING SHALL BE PROVIDED AS NEIGHBORHOOD PARKING. NEIGHBORHOOD PARKING SHALL BE PROVIDED AS NEIGHBORHOOD PARKING.

- LEGEND**
- NEIGHBORHOOD PARK (OB)
 - OPEN SPACE / DRAINAGE
 - FLOOD PLAIN
 - POCKET PARK
- TRAILS**
- CITY OF KYLE KILM CREEK PRESERVE NATURE TRAIL
 - MEANDERING CONCRETE TRAILS ALONG PRIMARY CIRCULATION ROUTES
 - MEANDERING TRAILS WITHIN PUDS / OPEN SPACE
 - DESIGNATED ROUTE FOR JOGGING CIRCUIT
 - COMMUNITY GARDENS

NOTE: OPEN SPACE AND PARKLAND SHALL BE PHASSED AND PROVIDED AS THE PROJECT IS DEVELOPED AND PLATTED OVER TIME. FINAL LAYOUT SHALL BE MODIFIED ACCORDING TO CONCEPT PLAN.



PECAN WOODS
PARKS, TRAILS & OPEN SPACE PLAN
HAYS COUNTY, TX



EXHIBIT E-1
DESCRIPTION OF PARKS, TRAILS AND OPEN SPACE

Community Amenity Center

The Community Amenity Center serves as the gathering space and recreation center for the residents of the entire Pecan Woods community. It shall be a minimum of three (3) acres and contain a combination of turf, grass, landscape and groundcover, and hardscape areas. On-site parking may be provided, as well as parking on adjacent streets. Facilities may include a hardscaped plaza, shade structures, restrooms, basketball court(s), picnic tables, playground equipment, pool, and meeting room(s).

Parks and Open Space

Adequate parks and open space programmed for a variety of uses in close proximity to residents is a requirement for a successful and sustainable community. The types of parks vary with their purpose and location within the community. To meet the needs of Pecan Woods residents, there are six types of parks and open space amenities proposed; neighborhood parks, pocket parks, active or passive open space areas, paseos, community garden, and trails.

Neighborhood Parks

These parks serve as the gathering spaces and recreation amenities for the neighborhoods within the Pecan Woods community. The parks shall be a minimum of two (2) acres each and contain a combination of turf, grass, landscape and groundcover, and hardscape areas. On-site parking may be provided, as well as parking on adjacent streets. Facilities may include shade structures, restrooms, basketball court(s), picnic tables, and playground equipment.

Pocket Parks

These parks are dispersed throughout the community to meet the daily recreational needs of families; particularly those with small children. They are generally located adjacent to paseos within or between individual neighborhoods, with a minimum size of one-quarter (1/4) acre and contain a combination of turf, grass, landscape and groundcover. They may also contain minor hardscape areas and play equipment surrounded by softscape. They are pedestrian in nature, but parking will be available on adjacent streets. Facilities may include small turf areas for passive play, small shade structures, picnic tables, and playground equipment primarily for young children.

Active or Passive Open Space Areas

These facilities consist of natural areas, ponds and basins to provide active or passive recreation opportunities for Pecan Woods residents. These areas may contain a combination of native landscape, groundcover and turf areas for trails and other active or passive recreation opportunities. A portion of drainage basins may be used as active or passive recreation areas by staging detention volumes through terraced bottom elevations so higher areas remain free from inundation during high-frequency/low-volume storms (< 25-year events).

Paseos

These areas lie within, between, or adjacent to the various neighborhoods and may contain trails, naturalistic stormwater conveyance and minor utility easements, as shown on the Pecan Woods Parks, Trails and Open Space Plan, **Exhibit E**. Meandering trails within paseos connect residential streets within neighborhoods to pocket parks, other trails, and surrounding destinations. They may contain a combination of landscape and groundcover, minor turf areas, and benches.

Community Garden

The Community Garden shall be a minimum of ten (10) acres with one location adjacent to the flood plain within the Pecan Woods community. The Community Garden will be Dedicated to the City of Kyle Parks Department, but will be the responsibility of the Home Owners Association (HOA) to maintain the facility. On-site parking may be provided, as well as parking on adjacent streets. Facilities may include shade structures, restrooms and picnic tables. It will offer a vibrant and open space for volunteers, students and residents to come together to plant seeds, harvest fruits, vegetables and give the residents of Pecan Woods and surrounding Development the opportunity to be happy and healthy without going to the local grocery/convenience store.

Trails

Trail types vary with their purpose and hierarchy of importance. Trails adjacent to Primary Circulation Routes serve as expedient routes to meet daily needs, such as walking to school, the store, a community meeting, or work. Trails within paseos and open space areas serve as the “scenic route”, offering a more relaxing experience by combining exercise with the enjoyment of the country setting.

A designated route within the proposed trail system provides a jogging circuit. This route may be surfaced with material other than concrete to provide an appropriate jogging surface while maintaining a natural setting. The route of the circuit typically begins at a Neighborhood Park, and circulates through the community as shown on the Pecan Woods Parks, Trails and Open Space Plan as depicted in **Exhibit E**.

Trails and jogging paths shall be constructed in phases to coincide with the overall development of the master plan and the location of these trails and paths as shown on the plan are subject to change as necessary.

The three types of pedestrian routes within Pecan Woods are described as follows:

Primary Circulation Routes

The primary pedestrian routes within Pecan Woods provide opportunities for exercise and are the main linkages and most direct routes from trip origins within neighborhoods to the school, parks, commercial sites and external destinations. These primary pedestrian routes are located parallel to the major road in the community on one or both sides of the travel lanes, but are enhanced to provide a safer and more enjoyable experience. The trails lie within parkways of varying widths; meander within the parkways; are separated from the street; may be concrete, decomposed granite, or other surfacing material; and connect to adjacent neighborhoods at intermittent points along their routes.

Meandering Trails within Paseos and Open Space

These trails provide a secondary pedestrian route. These provide the opportunity to enjoy the open space amenities and are for exercise and enjoyment, as well as getting between origins and destinations within the community. These trails may be surfaced in concrete, decomposed granite, or other material and are aligned within paseos between or adjacent to neighborhoods. These trails may connect to elements of the Plum Creek Preserve Nature Trail to provide regional pedestrian access.

City of Kyle Plum Creek Preserve Nature Trail

These trails provide continuous pedestrian route of the Plum Creek Preserve Nature Trail along Plum Creek. These trails will be dedicated to the City of Kyle Parks Department and be converted to 8' wide concrete trails. The completion of the Plum Creek Preserve Nature Trail will provide the connection between the individual homes within neighborhoods along Plum Creek to destinations and other levels of pedestrian circulation from Kyle Lake to Simon Middle School.

**EXHIBIT E-2
PARKLAND PHASING**

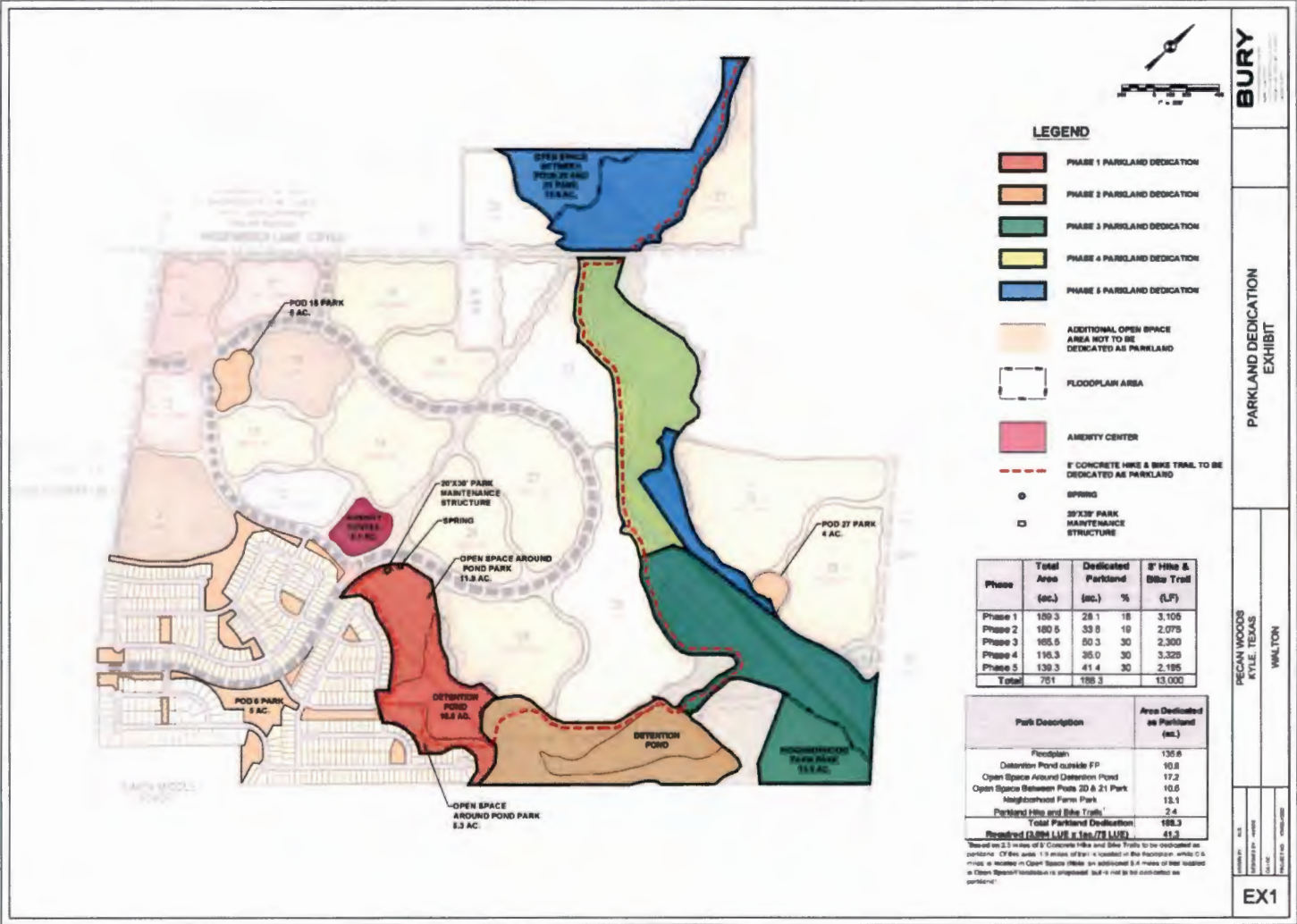
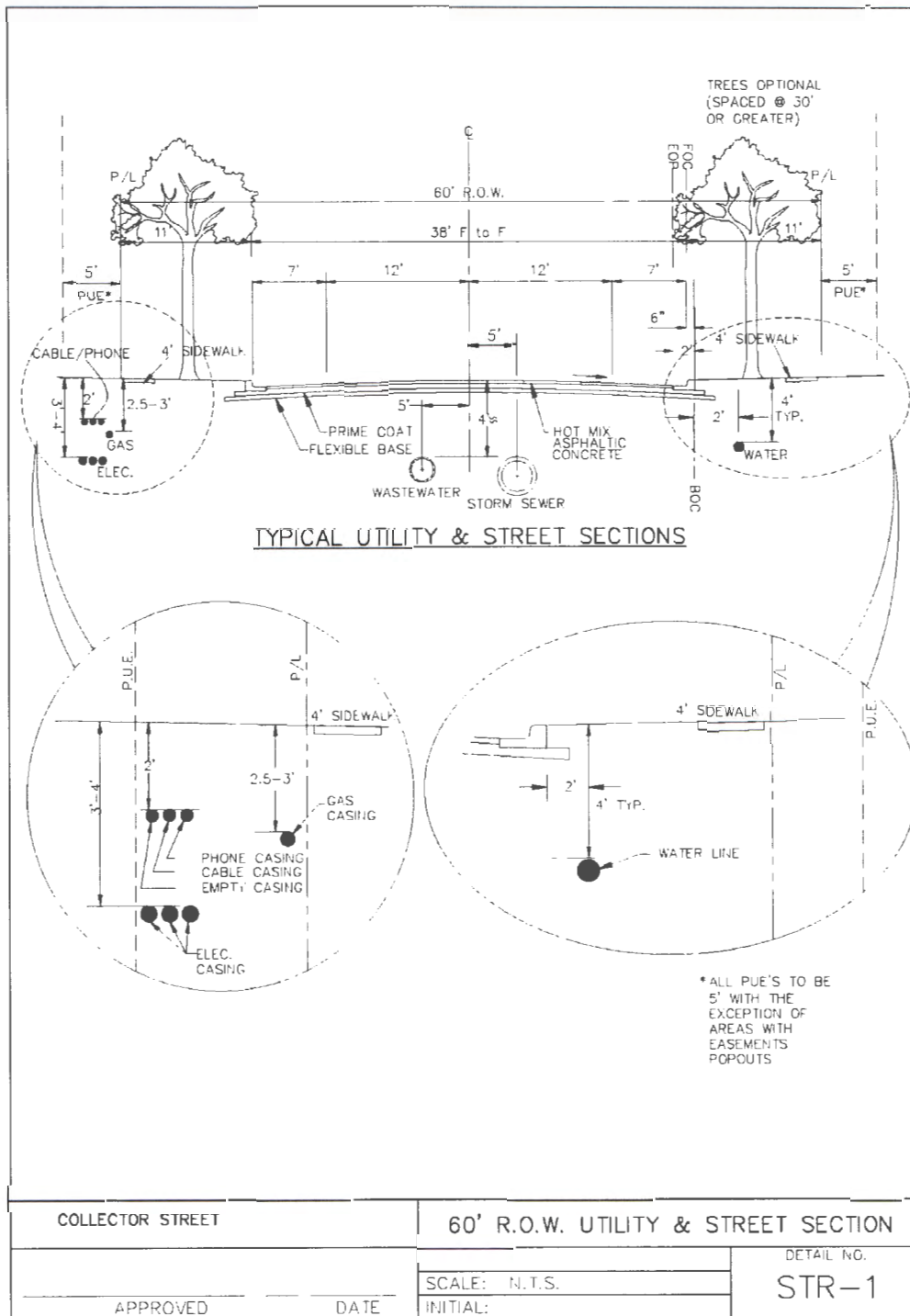
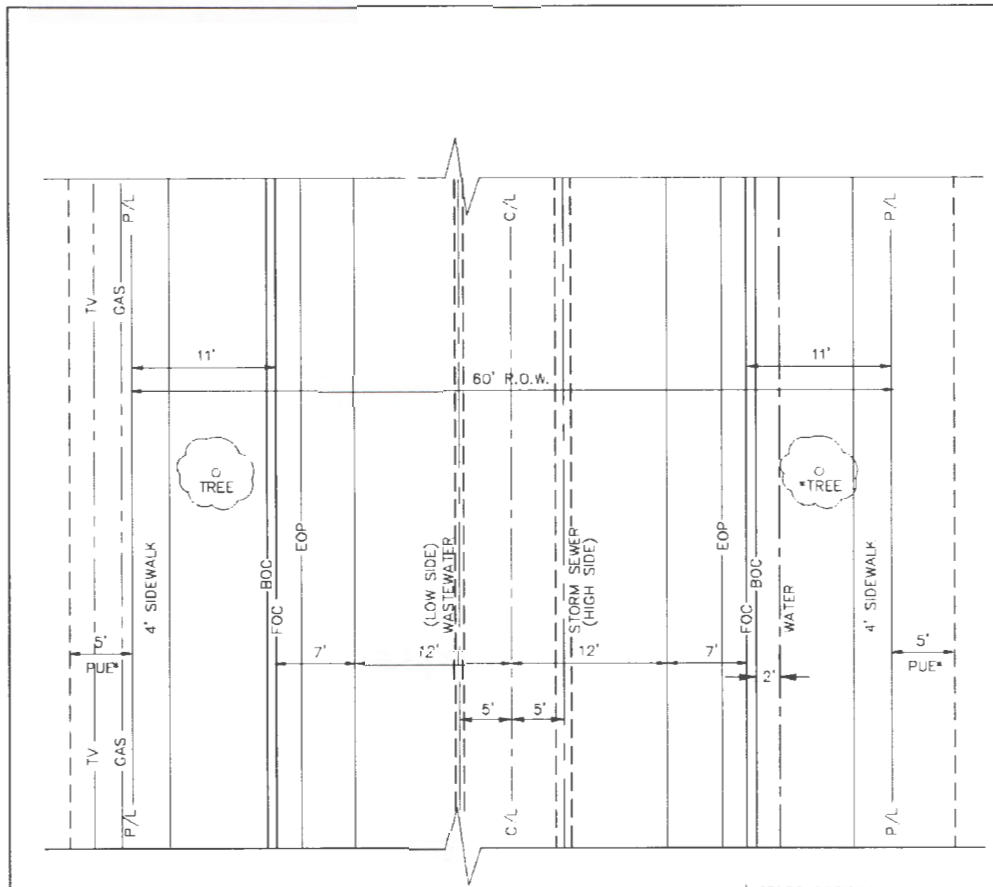

EXHIBIT E-3
PARKS MAINTENANCE BUILDING

- Owner in cooperation with the City will dedicate/construct a 20'x30' City of Kyle Parks Department Maintenance Building. The Maintenance Building will be a Pre-Engineered Metal Building (PEMB) or similar material located either within the Phase 1 Parkland or HOA owned and maintained land in Phase 1 of the Project, such location to be determined by Owner at Owner's discretion. If the Maintenance Building is constructed on HOA owned land, then the Owner will dedicate to the City Parks Department any easement necessary to provide access to the Maintenance Building.
- The Maintenance Building will follow all architecture guidelines set forth within the Development Agreement and/or the Covenants, Conditions and Restrictions for the Project.
- The Maintenance Building will be constructed with a concrete slab, 10' concrete apron along the front of the building, at a minimum one overhead garage door and a \$10,000 allowance for interior (office/bathroom) finish out.
- All park equipment will need to be stored inside the Maintenance Building at the end of the day or otherwise out of sight of any neighbors or surrounding traffic.
- The City shall maintain the Maintenance Building.
- If fencing is required, fencing will need to be approved by Owner and/or HOA, and installed by City of Kyle Parks Department at its cost.
- City of Kyle Parks Department shall respect all HOA rules and regulations regarding use of motorized equipment, mowers, leaf blowers, trimmers, etc. (i.e. quiet hours).

EXHIBIT F
TYPICAL CROSS SECTIONS





* TREES OPTIONAL
(SPACED @ 30'
OR GREATER)

TYPICAL UTILITY & STREET PLAN VIEW

* ALL PUE'S TO BE
5' WITH THE
EXCEPTION OF
AREAS WITH
EASEMENTS
POPOUTS

COLLECTOR STREET		60' R.O.W. UTILITY & STREET PLAN VIEW	
APPROVED _____		SCALE: N.T.S.	DETAIL NO. STR-1-1
DATE _____		INTEGRAL	

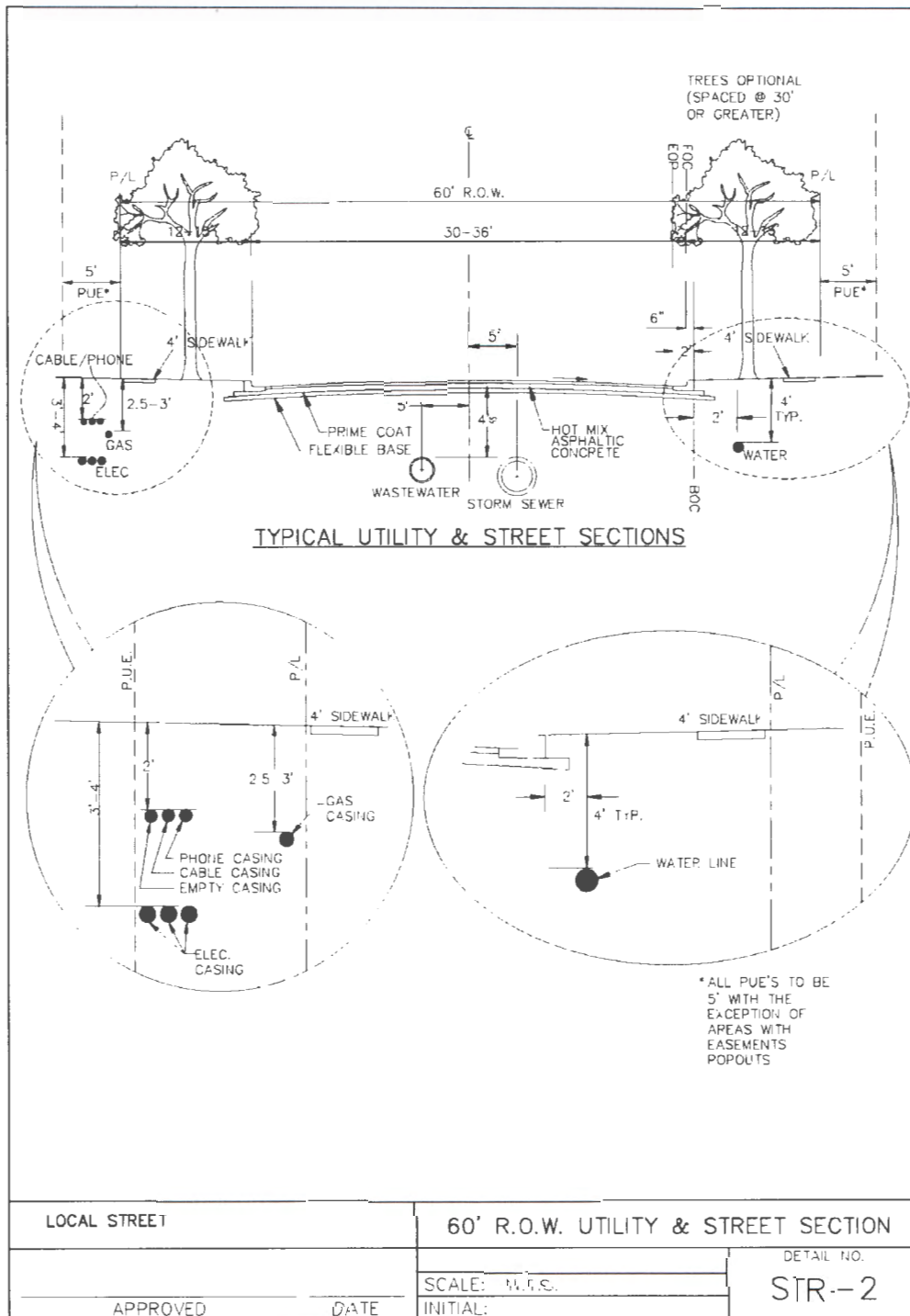

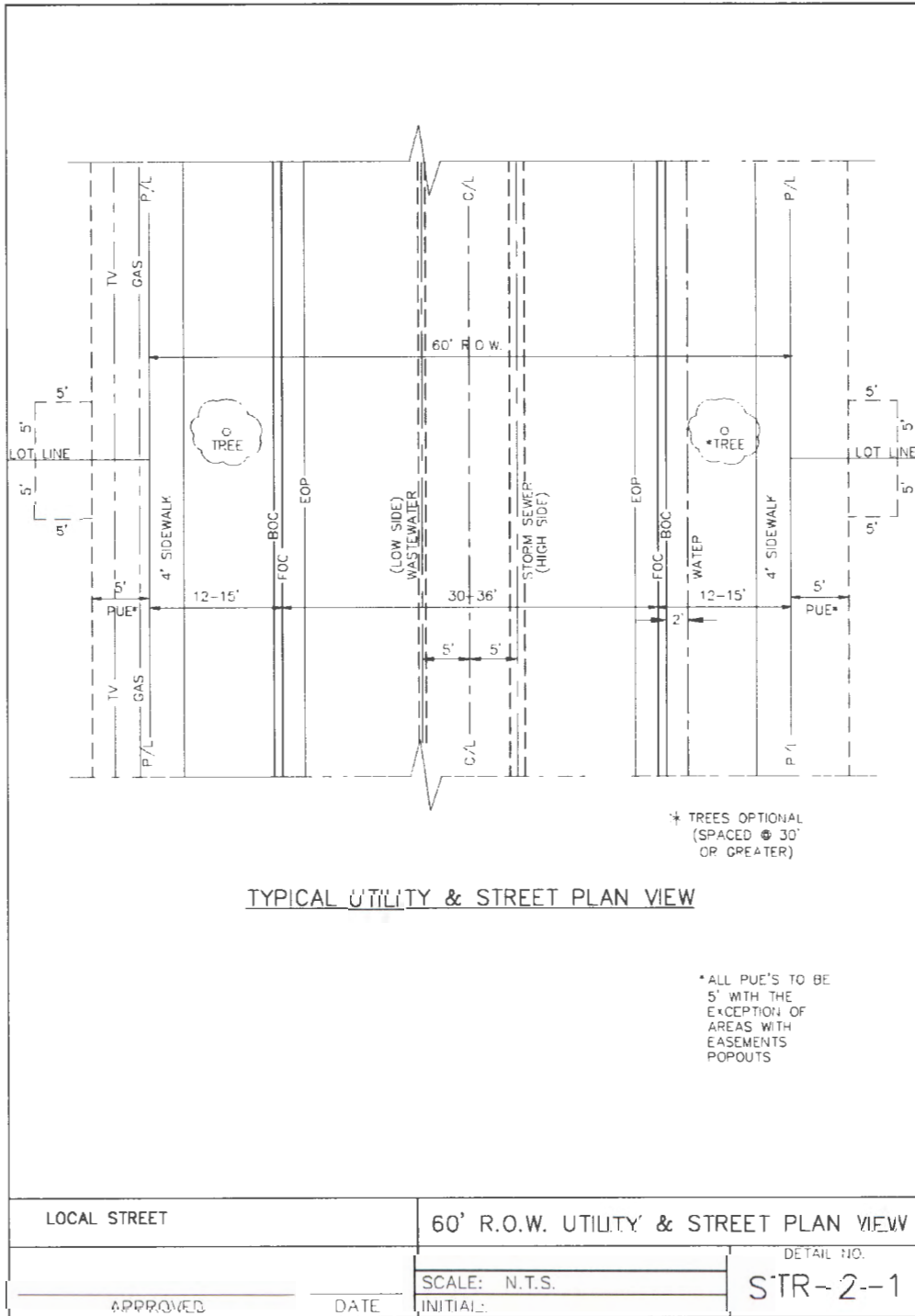

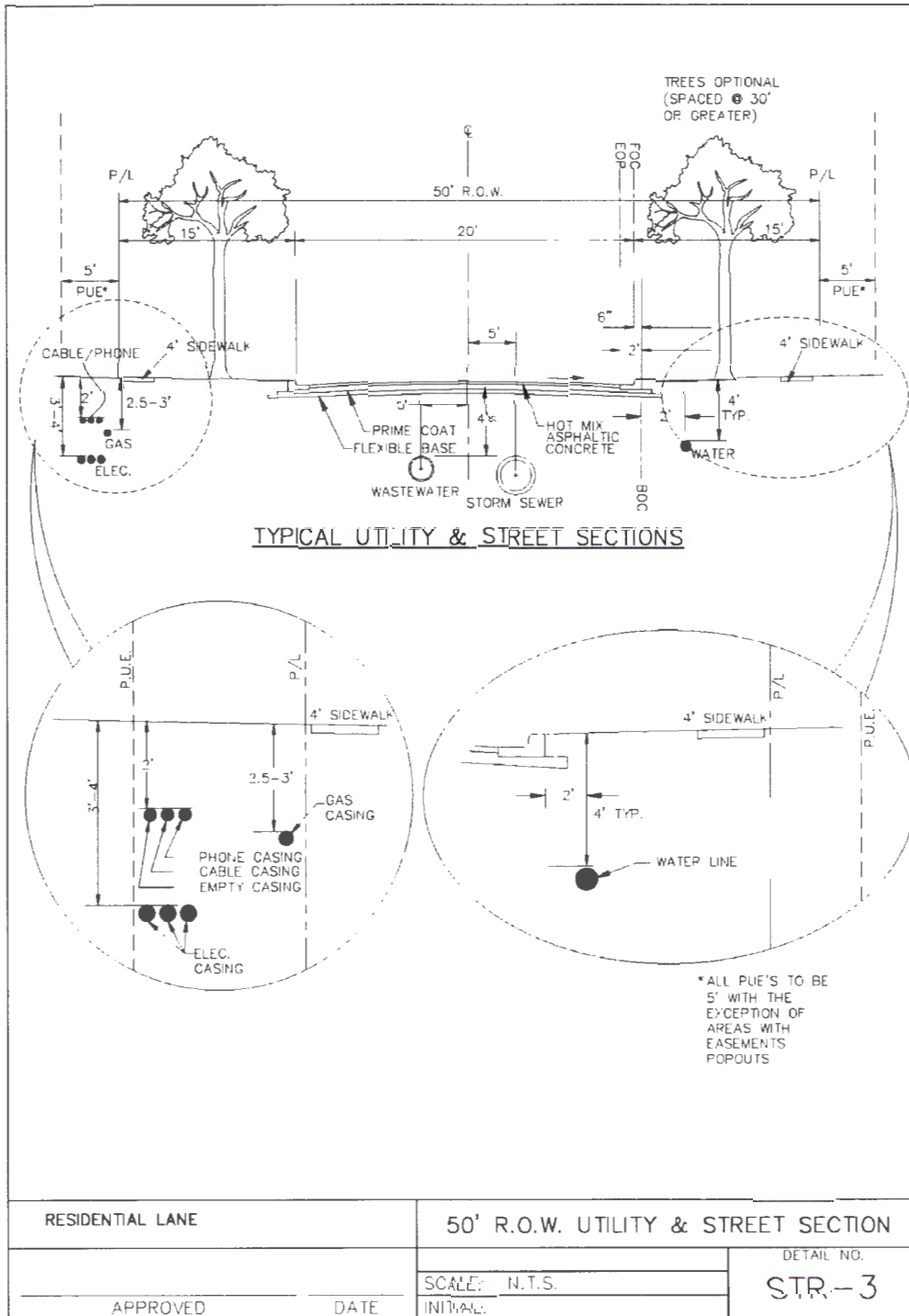

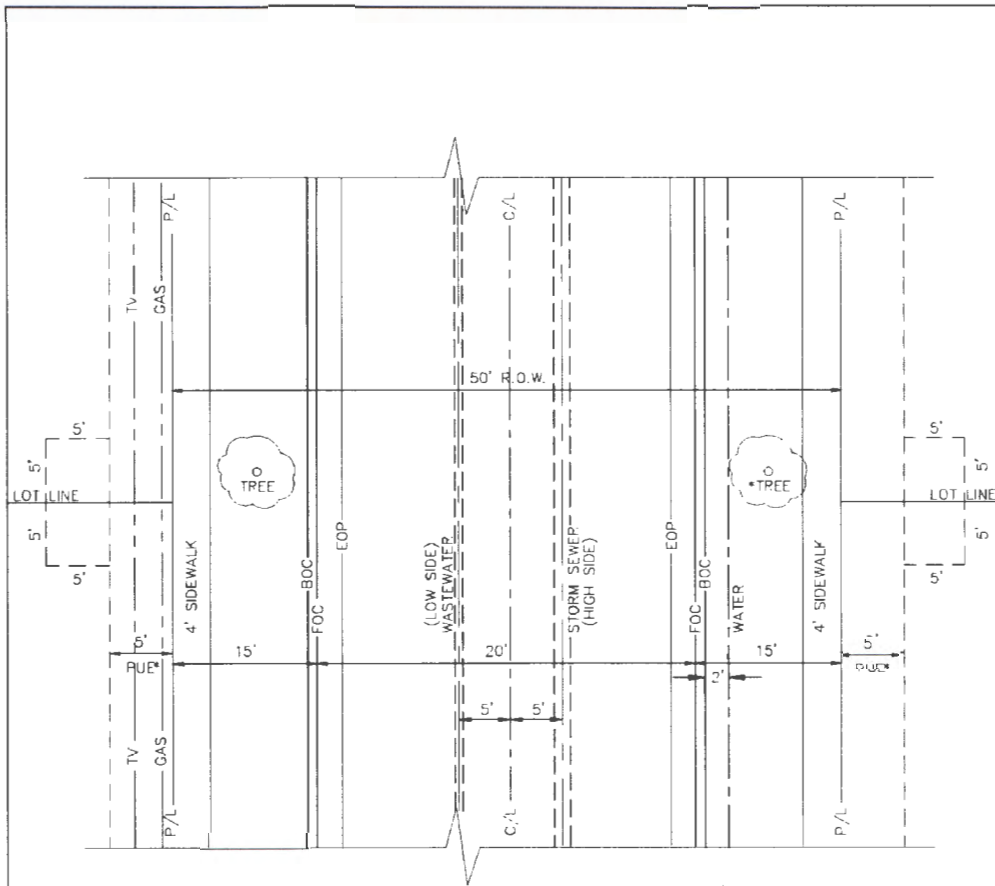

* TREES OPTIONAL
(SPACED @ 30'
OR GREATER)

TYPICAL UTILITY & STREET PLAN VIEW

* ALL PUE'S TO BE
5' WITH THE
EXCEPTION OF
AREAS WITH
EASEMENTS
POPOUTS

RESIDENTIAL LANE		50' R.O.W. UTILITY & STREET PLAN VIEW	
APPROVED _____ DATE _____		SCALE: N.T.S.	DETAIL NO.
		INITIAL: _____	STR-3-1

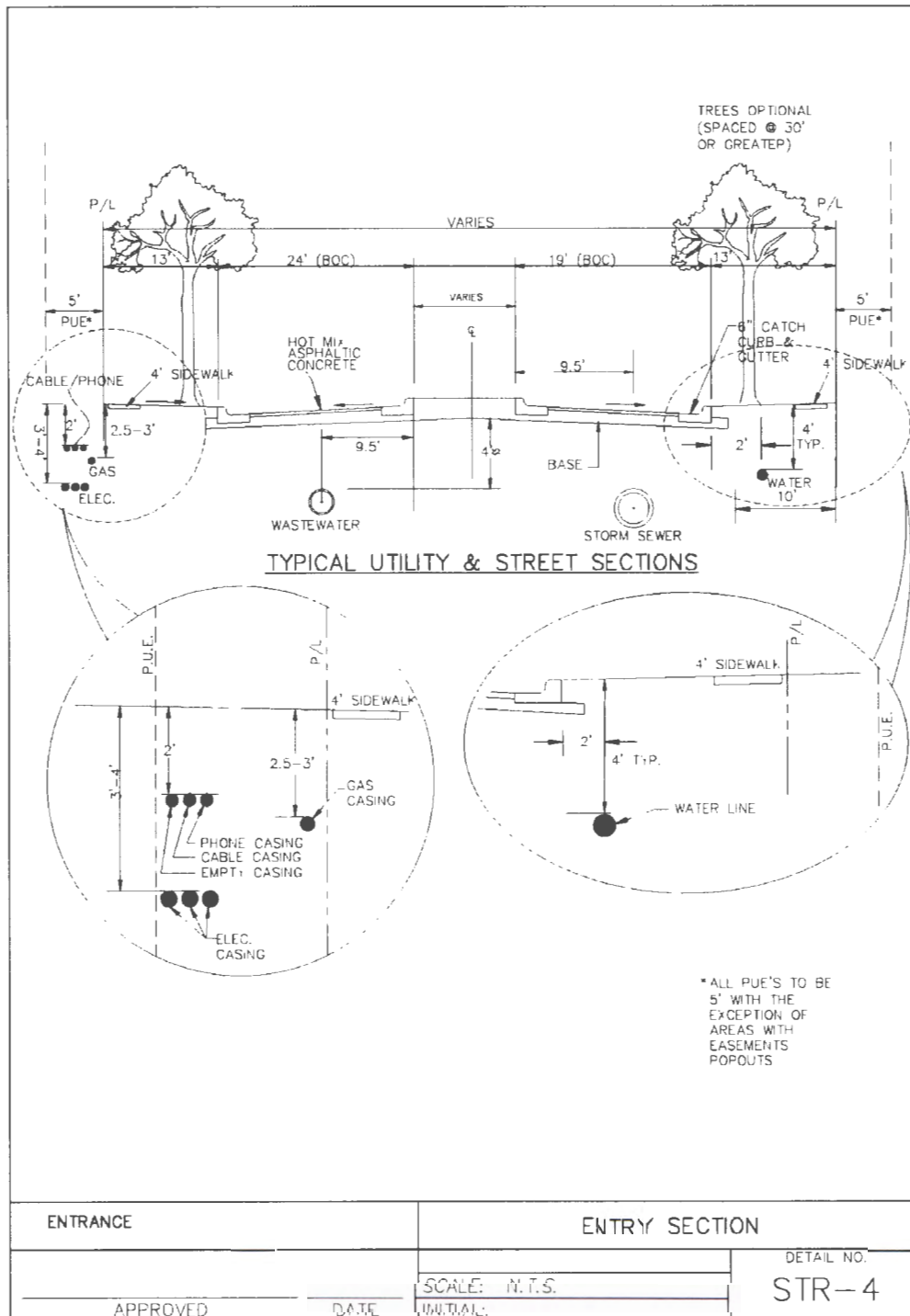

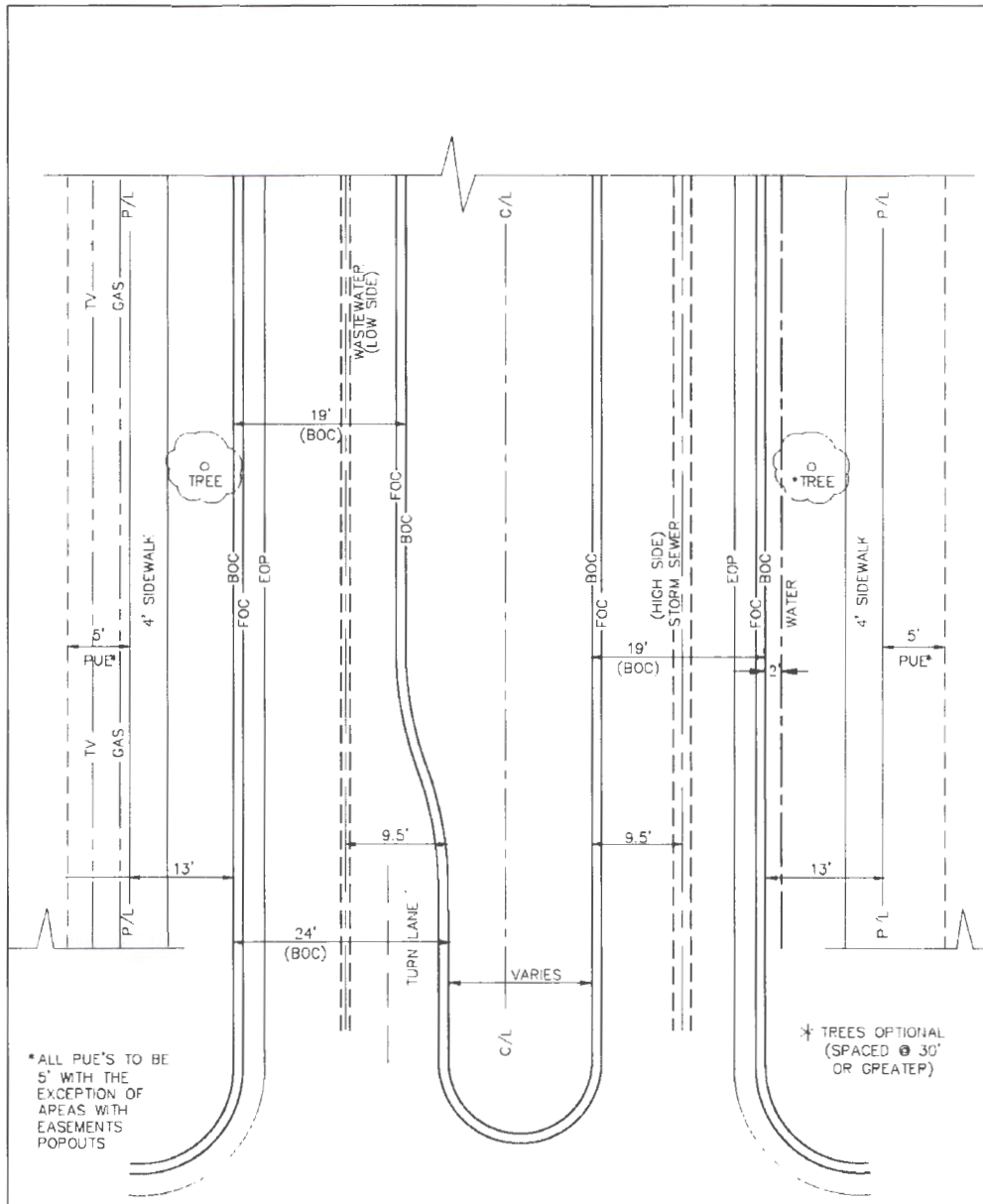

TYPICAL UTILITY & STREET PLAN VIEW

ENTRANCE	ENTRY PLAN VIEW	
APPROVED _____ DATE _____	SCALE: N.T.S. INITIAL: _____	DETAIL NO. STR-4-1A

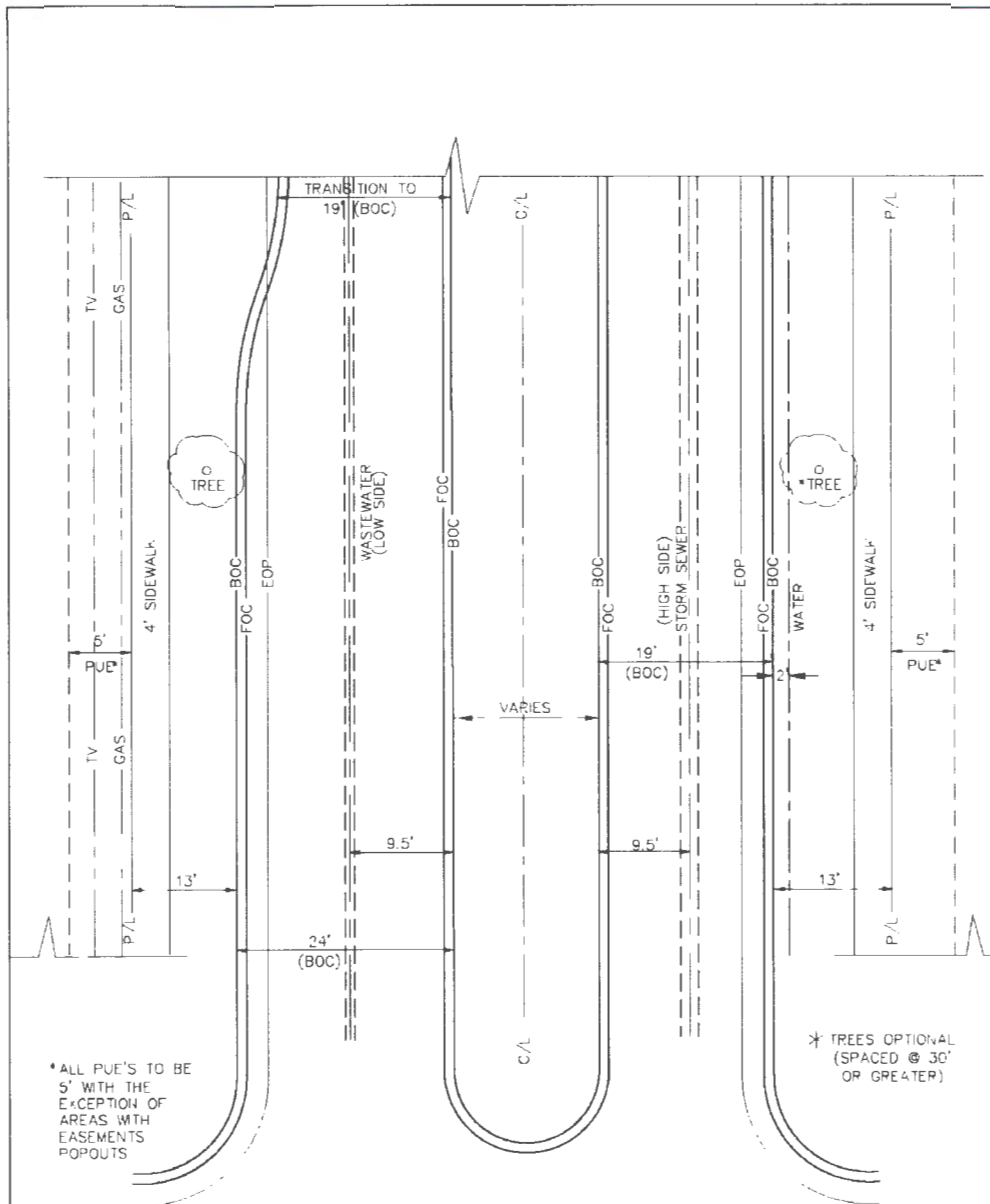

TYPICAL UTILITY & STREET PLAN VIEW

ENTRANCE		ENTRY PLAN VIEW	
		SCALE: N.T.S.	DETAIL NO.
APPROVED	DATE	INITIAL:	STR-4-1B

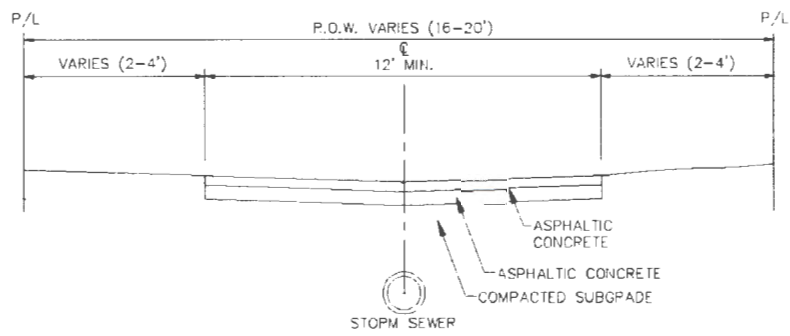

TYPICAL UTILITY & ALLEY SECTION

ALLEY	ALLEY UTILITY & STREET SECTION	
	SCALE: N.T.S.	DETAIL NO.
APPROVED	DATE	STR-5
	INITIAL:	

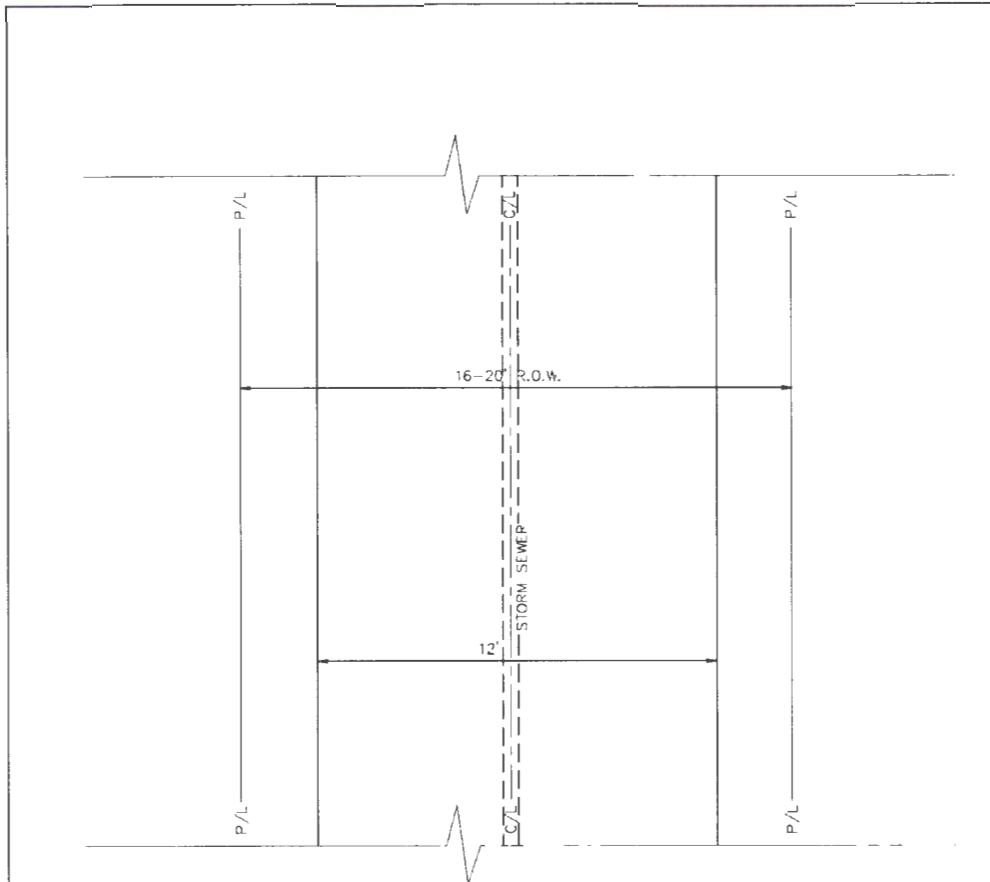

TYPICAL UTILITY & STREET PLAN VIEW

ALLEY		ALLEY UTILITY & STREET PLAN VIEW	
		SCALE: N.T.S.	DETAIL NO.
APPROVED	DATE	INITIALS	STR-5-1

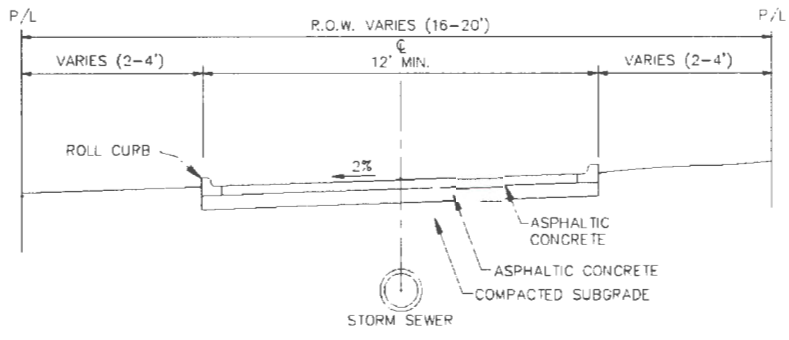

TYPICAL UTILITY & ALLEY SECTION

DRIVEWAY ON THE HIGH SIDE

ALLEY		ALLEY UTILITY & STREET SECTION	
		SCALE: N.T.S.	DETAIL NO.
APPROVED	DATE	INITIAL:	STR-6

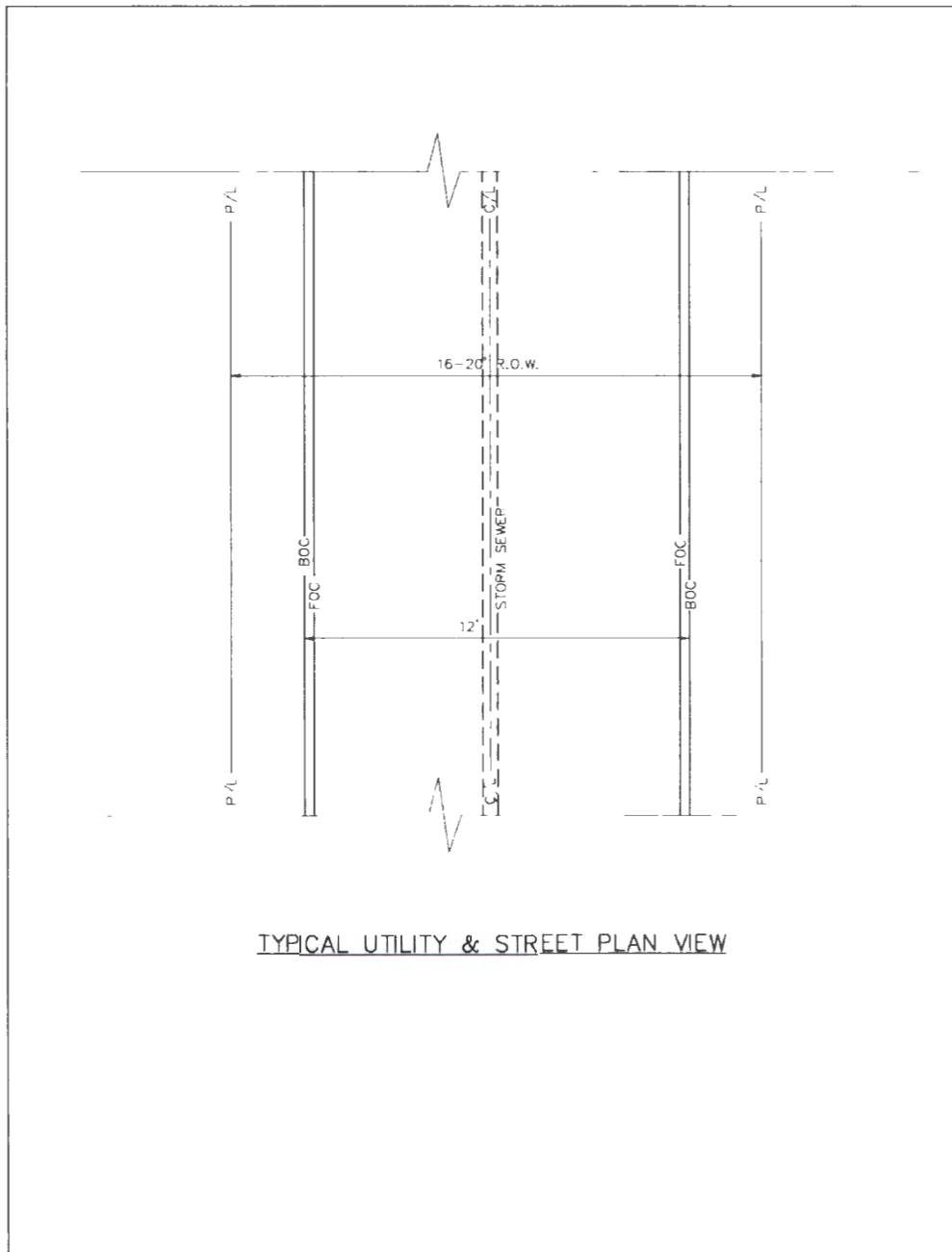

TYPICAL UTILITY & STREET PLAN VIEW

ALLEY		ALLEY UTILITY & STREET PLAN VIEW	
		DETAIL NO.	
APPROVED		SCALE: N.T.S.	STR-6-1
DATE		INITIAL:	

August 19, 2016

WALTON TEXAS, LP,
a Texas limited partnership

By: Walton Texas GP, LLC,
a Texas limited liability company,
its General Partner

By: Walton International Group, Inc.,
a Nevada corporation,
its Manager

By: John Vick
Name: John Vick
Title: Authorized Signatory

STATE OF TEXAS §
 §
COUNTY OF Tarrant §

BEFORE ME, the undersigned Notary Public in and for the State of Texas, on this day personally appeared John Vick, an Authorized Signatory of Walton International Group, Inc., a Nevada corporation, Manager of Walton Texas GP, LLC, a Texas limited liability company, General Partner of Walton Texas, LP, a Texas limited partnership, on behalf of said limited partnership, in the capacity herein stated.

GIVE UNDER MY HAND AND SEAL OF OFFICE this 19th day of August, 2016.

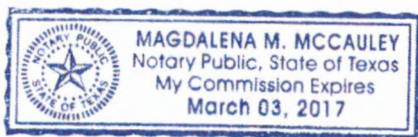

Magdalena M. McCauley
Notary Public in and for the State of Texas

WALTON PECAN WOODS, LP,
a Delaware limited partnership

By: WPW GP, LLC,
a Delaware limited liability company,
its General Partner

By: Walton Land Management (USA), Inc.,
a Delaware corporation,
its Manager

By: 
Name: John Vick
Title: Authorized Signatory

STATE OF TEXAS §
COUNTY OF Tarrant §

BEFORE ME, the undersigned Notary Public in and for the State of Texas, on this day personally appeared John Vick, an Authorized Signatory of Walton Land Management (USA), Inc., a Delaware corporation, Manager of WPW GP, LLC, a Delaware limited liability company, General Partner of Walton Pecan Woods, LP, a Delaware limited partnership, on behalf of said limited partnership, in the capacity herein stated.

GIVE UNDER MY HAND AND SEAL OF OFFICE this 19th day of August, 2016.

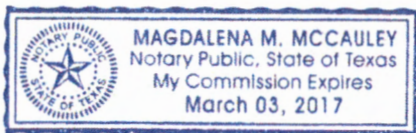

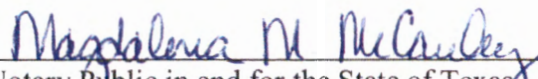
Notary Public in and for the State of Texas

August 19, 2016

WPW DEVELOPMENT SUB, LP,
a Delaware limited partnership

By: Walton Pecan Woods Development GP, LLC,
a Delaware limited liability company,
its General Partner

By: Walton Pecan Woods Development, LP,
a Delaware limited partnership,
its Manager

By: WPW GP, LLC,
a Delaware limited liability company,
its General Partner

By: Walton Land Management (USA), Inc.,
a Delaware corporation,
its Manager

By: [Signature]
Name: John Vick
Title: Authorized Signatory

STATE OF TEXAS §
 §
COUNTY OF Tarrant §

BEFORE ME, the undersigned Notary Public in and for the State of Texas, on this day personally appeared John Vick, an Authorized Signatory of Walton Land Management (USA), Inc., a Delaware corporation, Manager of WPW GP, LLC, a Delaware limited liability company, General Partner of Walton Pecan Woods Development, LP, a Delaware limited partnership, Manager of Walton Pecan Woods Development GP, LLC, a Delaware limited liability company, General Partner of WPW Development Sub, LP, a Delaware limited partnership, on behalf of said limited partnership, in the capacity herein stated.

GIVE UNDER MY HAND AND SEAL OF OFFICE this 19th day of August, 2016.

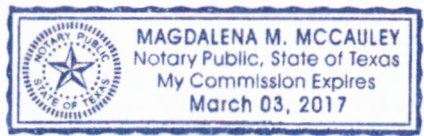

[Signature]
Notary Public in and for the State of Texas

EXHIBIT A

PROPERTY DESCRIPTION

10/10/2016 11:24 AM F:\JH

EXHIBIT "A"

Tract I:

DESCRIBING A 696.20 ACRE TRACT OF LAND BEING A PART OF THE WILLIAM HEMPHILL SURVEY A-221 AND THE ALBERT PACF SURVEY A-367, HAYS COUNTY, TEXAS, SAID TRACT OF LAND ALSO BEING ALL OF THE FOLLOWING TRACTS OF LAND:

- 1) 127.789 ACRE TRACT AND 248.01 ACRE TRACT DESCRIBED IN A GENERAL WARRANTY DEED TO FM 150 AND HEIDERREICH, L.P., A TEXAS LIMITED PARTNERSHIP EXECUTED ON JULY 15, 2005 AND RECORDED IN VOLUME 2730 PAGE 107, DEED RECORDS OF SAID COUNTY,
 - 2) 249.51 ACRE TRACT DESCRIBED IN A GENERAL WARRANTY DEED TO FM 150 AND HEIDERREICH, L.P., A TEXAS LIMITED PARTNERSHIP EXECUTED ON NOVEMBER 16, 2005 AND RECORDED IN VOLUME 2813 PAGE 415, DEED RECORDS OF SAID COUNTY,
 - 3) 72.47 ACRE TRACT DESCRIBED IN A SPECIAL WARRANTY DEED TO FM 150 AND HEIDERREICH, L.P., A TEXAS LIMITED PARTNERSHIP EXECUTED ON MARCH 9, 2007 AND RECORDED IN VOLUME 3124 PAGE 730, DEED RECORDS OF SAID COUNTY,
- SAID 696.20 ACRE TRACT OF LAND BEING MORE PARTICULARLY DESCRIBED BY METES AND BOUNDS AS FOLLOWS:

BEGINNING, at an iron rod with aluminum cap stamped 4341 found at the western most south corner of said 127.789 acre tract, same being at the west corner of that certain 10.811 acre tract of land described in a deed to Hays Consolidated Independent School District recorded in Volume 2606 Page 885, Deed Records of said County and in the northeast right-of-way line of Farm Highway No. 150 (FM 150) (80' R.O.W.);

THENCE, with the southwest line of said 127.789 acre tract and said 248.01 acre tract, same being the northeast line of said FM 150, the following three courses

- 1) N47°03'16"W, 985.61 feet to an iron rod with aluminum cap stamped 4341 found,
- 2) Along a curve to the right having a radius of 2254.28 feet, an arc length of 379.68 feet, a central angle of 9°39'00" and a chord which bears N42°14'17"W, 379.23 feet to an iron rod with plastic cap stamped UDG #2433 set from which a concrete monument found bears S52°32'17"W, 80.29 feet;
- 3) N37°26'17"W, 2921.85 feet to an iron rod with plastic cap stamped UDG #2433 set at the south corner of that certain 0.9 of an acre tract of land described in a deed to Hemphill School District No. 5 as recorded in Volume 209 Page 623, Deed Records of said County,

THENCE, with the southeast, northeast and northwest lines of said 0.9 of an acre tract, the following three courses:

- 1) N43°08'23"E, 307.63 feet to an iron rod with aluminum cap stamped Pro Tech found,
- 2) N37°26'10"W, 128.35 feet to an iron rod with aluminum cap stamped Pro Tech found,

- 3) S43°10'02"W, 307.61 feet to an iron rod with plastic cap stamped UDG #2433 set at the west corner of said 0.9 of an acre tract, same being in the northeast line of said FM 150;

THENCE, with the southwest line of said 248.01 acre tract, same being the northeast line of said FM 150, N37°26'17"W, 221.73 feet to a calculated point within a utility pole at the west corner of said 248.01 acre tract, same being in the southeast line of County Road 152 (CR 152) (R.O.W. varies);

THENCE, with the northwest line of said 248.01 acre tract, same being the southeast line of said CR 152, N43°23'22"E, at 20.00 feet passing an iron rod with plastic cap stamped UDG #2433 set for reference, continuing for a total distance of 2760.21 feet to an iron rod with plastic cap stamped UDG #2433 set at the northern most north corner of said 248.01 acre tract, same being the west corner of that certain 3.0 acre tract of land described in a deed to Sally R. Windham as recorded in Volume 2354 Page 482, Deed Records of said County;

THENCE, with the southwest and southeast lines of said Windham tract, the following two courses;

- 1) S46°59'17"E, 835.19 feet to an iron rod found;
- 2) N43°23'49"E, 313.18 feet to an iron rod found at the east corner of said Windham tract, same being the southern most north corner of said 248.01 acre tract;

THENCE, with the northeast line of said Windham tract and another 3.0 acre tract of land described in a deed to Sally R. Windham as recorded in Volume 2261 Page 672, Deed Records of said County, N47°00'31"W, 835.23 feet to an iron rod found at the north corner of said Windham tract recorded in Volume 2261 Page 672 and in the southeast line of said CR 152;

THENCE, with the southeast line of said CR 152, N44°16'07"E, 29.14 feet to a 1"x1" square iron rod found at the west corner of said 72.47 acre tract of land;

THENCE, with the northwest line of said 72.47 acre tract, same being the southeast line of said CR 152, the following three courses,

- 1) N41°47'21"E, 609.01 feet to an iron rod with plastic cap stamped UDG #2433 set;
- 2) S47°24'04"E, 10.14 feet to an iron rod with plastic cap stamped UDG #2433 set;
- 3) N42°36'29"E, 550.00 feet to an iron rod with cap stamped 5296 found at the north corner of said 72.47 acre tract, same being in the southwest line of that certain 72.266 acre tract of land described in a deed to Frazier Land & Cattle Company, L.L.C. as recorded in Volume 1249 Page 415, Deed Records of said County from which an iron rod found bears N30°52'27"W, 10.31 feet;

THENCE, with the northeast line of said 72.47 acre tract, same being the southwest line of said 72.266 acre tract, the following six courses;

- 1) S30°56'20"E, 279.59 feet to an iron pipe found;
- 2) S84°47'08"E, 150.70 feet to a fence post found;
- 3) N88°18'39"E, 36.37 feet to a fence post found,
- 4) N80°40'50"E, 92.75 feet to a fence post found,

- 5) N77°28'48"E, 54.84 feet to an iron rod found,
- 6) N75°07'22"E, 356.15 feet to an iron rod found at the southwest corner of that certain 6.170 acre tract of land described in a deed to Kerry Dabbs and Theresa G. Dabbs as recorded in Volume 1979 Page 301, Deed Records of said County;

THENCE, continuing with the northeast line of said 72.47 acre tract, same being the south line of said 6.170 acre tract, N74°58'05"E, 348.74 feet to a fence post found at the southeast corner of said 6.170 acre tract, same being in the southwest line of said 72.266 acre tract described in a deed to Frazier Land & Cattle Company, L.L.C. as recorded in said Volume 1249 Page 415;

THENCE, continuing with the northeast line of said 72.47 acre tract, same being the south line of said 72.266 acre tract, N89°54'28"E, 16.78 feet to a fence post found at the southwest corner of that certain 6.041 acre tract of land described in a deed to Edward Chabarría as recorded in Volume 2531 Page 23, Deed Records of said County;

THENCE, continuing with the northeast line of said 72.47 acre tract, same being the southwest line of said 6.041 acre tract, S43°24'06"E, 346.43 feet to a fence post found at the southeast corner of said 6.041 acre tract and at the northwest corner of that certain 6.050 acre tract of land described in a deed to Troy C. Benedict and Dianne L. Benedict as recorded in Volume 2784 Page 400, Deed Records of said County;

THENCE, with the northeast and west line of said 72.47 acre tract, same being the southwest and east line of said 6.050 acre tract and the east line of a 5.996 acre tract also described in said deed to Troy C. Benedict and Dianne L. Benedict as recorded in Volume 2784 Page 400, the following eleven courses;

- 1) S42°59'00"E, 265.64 feet to a fence post found;
- 2) S02°40'16"W, 220.30 feet to a fence post found;
- 3) N69°43'25"E, 117.08 feet to an iron rod with plastic cap stamped UDG #2433 set;
- 4) N60°49'02"E, 106.76 feet to an iron rod found;
- 5) N53°56'58"E, 20.55 feet to a fence post found;
- 6) N56°40'00"E, 135.58 feet to a fence post found;
- 7) N54°11'17"E, 57.03 feet to an iron rod found;
- 8) N50°52'19"E, 86.40 feet to an iron rod with plastic cap stamped UDG #2433 set;
- 9) N51°10'41"E, 72.23 feet to an iron rod found;
- 10) N51°19'44"E, 271.46 feet to a fence post found;
- 11) S43°10'36"E, 33.96 feet to a fence post found at the southern most east corner of said 72.34 acre tract, same being a south corner of said 5.996 acre tract and in the northwest line of said 249.51 acre tract;

THENCE, with northwest line of said 249.51 acre tract, same being the southeast line of said 5.996 acre tract, N42°00'36"E, at approximately 87.5 feet passing a calculated point at the southeast corner of said 5.996 acre tract, same being the south corner of that certain 5.961 acre tract of land described in a deed to Jose M. Wong and Maria D. Wong and Maria L. Wong as recorded in Volume 2551 Page 366, Deed Records of said County, continuing for a total distance of 438.39 feet to an iron rod found at the east corner of said 5.961 acre tract, same

being at the south corner of that certain 6.234 acre tract of land described in a deed to Rufina O. Velasquez as recorded in Volume 2067 Page 38, Deed Records of said County;

THENCE, continuing with the northwest line of said 249.51 acre tract, same being the southeast line of said 6.234 acre tract, $N42^{\circ}04'27''E$, at approximately 231.5 feet passing a calculated point at the east corner of said 6.234 acre tract, same being at the south corner of that certain 6.512 acre tract of land described in a deed to Jose M. Montoya as recorded in Volume 3160 Page 656, Deed Records of said County, continuing at approximately 485.9 feet passing a calculated point at the east corner of said 6.512 acre tract, same being at the south corner of Lot 1, Anton Subdivision, as subdivision recorded in Book 4 Page 209, Plat Records of said County, continuing for a total distance of 695.58 feet to an iron rod with cap stamped 5780 found at the north corner of said 249.51 acre tract, same being in the southwest right-of-way line of County Road 153 (CR 153) (R.O.W. varies);

THENCE, with the northeast line of said 249.51 acre tract, same being the southwest line of said CR 153, the following three courses;

- 1) $S42^{\circ}17'53''E$, 2444.46 feet to an iron rod with plastic cap stamped UDG #2433 set;
- 2) $S43^{\circ}37'05''E$, 249.56 feet to an iron rod with plastic cap stamped UDG #2433 set;
- 3) $S44^{\circ}38'27''E$, 357.69 feet to an iron rod with cap stamped 5780 found at the east corner of said 249.51 acre tract, same being at the north corner of that certain 125 acre tract of land described in a deed to B. R. Wranitzky as recorded in Volume 133 Page 49, Deed Records of said County;

THENCE, with the southeast line of said 249.51 acre tract, same being the northwest line of said 125 acre tract, $S42^{\circ}35'05''W$, 3459.64 feet to an iron rod with cap stamped Pro Tech Eng found at the south corner of said 249.51 acre tract, same being at the east corner of said 127.789 acre tract, the west corner of said 125 acre tract and at the north corner of that certain 45.2855 acre tract of land described in a deed to Gary R. Hutzler and Nancy H. Hutzler as recorded in Volume 874 Page 676, Deed Records of said County;

THENCE, with the eastern most southeast line of said 127.789 acre tract, same being the northwest line of said 45.2855 acre tract, $S42^{\circ}43'32''W$, at approximately 1994.0 feet passing a calculated point at the west corner of said 45.2855 acre tract, same being at the north corner of that certain 10.0 acre tract of land described in a deed to Gary McMurrey as recorded in Volume 1680 Page 168, Deed Records of said County, continuing for a total distance of 2368.37 feet to an iron rod with aluminum cap stamped Ahlhardt 1987 found at the eastern most south corner of said 127.789 acre tract, same being at the west corner of said 10.0 acre tract, the north corner of that certain 34.905 acre tract of land described in a deed to Hays Consolidated Independent School District as recorded in Volume 1388 Page 870, Deed Records of said County and at the east corner of said 10.811 acre tract;

THENCE, with a southwest line of said 127.789 acre tract, same being the northeast line of said 10.811 acre tract, $N47^{\circ}05'05''W$, 360.13 feet to an iron rod with aluminum cap stamped Kent McMillan RPLS 4341 found at an interior corner of said 127.789 acre tract, same being at the north corner of said 10.811 acre tract,

THENCE, with the western most southeast line of said 127.789 acre tract, same being the northwest line of said 10.811 acre tract, the following two courses;

- 1) S42°43'31"W, 1288.04 feet to an iron rod with aluminum cap stamped 4341 found;
- 2) S42°40'04"W, 20.00 feet to the POINT OF BEGINNING and containing 696.20 acres.

Tract II:

DESCRIBING A 66.57 ACRE TRACT OF LAND BEING A PART OF THE ROBERT CARSON SURVEY A-135 AND THE ALBERT PACE SURVEY A-367, HAYS COUNTY, TEXAS, SAID TRACT OF LAND ALSO BEING ALL OF THAT CERTAIN 67.18 ACRE TRACT OF LAND DESCRIBED IN A GENERAL WARRANTY DEED TO FM 150 AND HEIDERREICH, L.P., A TEXAS LIMITED PARTNERSHIP EXECUTED ON NOVEMBER 2, 2005 AND RECORDED IN VOLUME 2804 PAGE 887, DEED RECORDS OF SAID COUNTY, SAID 66.57 ACRE TRACT OF LAND BEING MORE PARTICULARLY DESCRIBED BY METES AND BOUNDS AS FOLLOWS:

BEGINNING, at an iron rod with plastic cap stamped UDG #2433 set at the south corner of said 66.57 and said 67.18 acre tract, same being at the east corner of that certain 18.62 acre tract of land described in a deed to Randall G. Pendleton and Frances A. Pendleton as recorded in Volume 2477 Page 482, Deed Records of said County, same also being in the northwest right-of-way line of County Road No. 152 (R.O.W. varies) and from which an iron rod with cap stamped 3296 found at the south corner of said 18.62 acre tract bears S43°04'33"W, 2741.46 feet;

THENCE, with the southern most southwest line of said 66.57 and said 67.18 acre tract, same being the northeast line of said 18.62 acre tract, N46°55'02"W, 273.45 feet to an iron rod with plastic cap stamped UDG #2433 set at the north corner of said 18.62 acre tract;

THENCE, continuing with the southern most southwest line of said 66.57 and said 67.18 acre tract, N47°10'36"W, 671.80 feet to an iron rod with plastic cap stamped UDG #2433 set at the southern most west corner of said 66.57 and said 67.18 acre tract, same being the south corner of that certain 87.36 acre tract of land described in a deed to the City of Kyle as recorded in Volume 477 Page 870, Deed Records of said County from which an iron rod bears N47°07'40"W, 1465.83 feet to an iron rod found and N42°41'32"E, 1172.20 feet;

THENCE, with the southern most northwest line of said 66.57 and said 67.18 acre tract, same being a southeast line of said 87.36 acre tract, N42°55'28"E, 2130.72 feet to an iron rod with plastic cap stamped UDG #2433 set at an interior corner of said 66.57 and said 67.18 acre tract, same being at an east corner of said 87.36 acre tract;

THENCE, with the northern most southwest line of said 66.57 and said 67.18 acre tract, same being a northeast line of said 87.36 acre tract, the following five courses,

- 1) N22°53'51"W, 110.77 feet to a calculated point.

- 2) N18°52'51"W, 453.13 feet to an iron rod with plastic cap stamped UDG #2433 set;
- 3) N25°21'51"W, 83.35 feet to an iron rod with plastic cap stamped UDG #2433 set;
- 4) N46°00'51"W, 271.48 feet to an iron rod with plastic cap stamped UDG #2433 set;
- 5) N01°52'51"W, 20.74 feet to an iron rod with plastic cap stamped UDG #2433 set at the northern most west corner of said 66.57 and said 67.18 acre tract, same being an interior corner of said 87.36 acre tract,

THENCE, with the northern most northwest line of said 66.57 and said 67.18 acre tract, same being a southeast line of said 87.36 acre tract, N43°06'09"E, 283.21 feet to an iron rod with plastic cap stamped UDG #2433 set at the north corner of said 66.57 and said 67.18 acre tract, same being an east corner of said 87.36 acre tract and in a southwest line of that certain 120.41 acre tract of land described in a deed to Barry C. Wukasch as recorded in Volume 1276 Page 182, Deed Records of said County;

THENCE, with the northern most northeast line of said 66.57 and said 67.18 acre tract, same being a southwest line of said 120.41 acre tract, S47°31'54"E, 1047.44 feet to an iron rod found at a south corner of said 120.41 acre tract, same being a west corner of that certain 48.725 acre tract of land described in a deed to Umland Mercantile Company as recorded in Volume 1092 Page 811, Deed Records of said County;

THENCE, with the northern most northeast line of said 66.57 and said 67.18 acre tract, same being a southwest line of said 48.725 acre tract, S47°13'09"E, 556.85 feet to an iron rod with plastic cap stamped UDG #2433 set at the northern most east corner of said 66.57 and said 67.18 acre tract, same being in a southwest line of said 48.725 acre tract and at the north corner of that certain 0.5 of an acre tract of land described in a deed to A. D. Fuchs and wife, Caroline S. Fuchs as recorded in Volume 263 Page 245, Deed Records of said County;

THENCE, with the northern most southeast line of said 66.57 and said 67.18 acre tract, same being the northwest line of said 0.5 of an acre tract, S42°38'53"W, 104.15 feet to an iron rod with plastic cap stamped UDG #2433 set at an interior corner of said 66.57 and said 67.18 acre tract, same being at the west corner of said 0.5 of an acre tract;

THENCE, with the southern most northeast line of said 66.57 and said 67.18 acre tract, same being the southwest line of said 0.5 of an acre tract, S46°50'22"E, 195.52 feet to an iron rod with plastic cap stamped UDG #2433 set at the southern most east corner of said 66.57 and said 67.18 acre tract, same being the south corner of said 0.5 of an acre tract and in the northwest right-of-way line of said County Road No. 152;

THENCE, with the southern most southeast line of said 66.57 and said 67.18 acre tract, same being a northwest line of said County Road No. 152, the following five courses;

- 1) S42°36'17"W, 967.50 feet to an iron rod with plastic cap stamped UDG #2433 set;
- 2) N47°23'42"W, 5.00 feet to an iron rod with plastic cap stamped UDG #2433 set;

- 3) S42°36'17"W, 850.00 feet to an iron rod with plastic cap stamped UDG #2433 set;
- 4) S47°23'43"E, 5.00 feet to a nail found;
- 5) S43°04'33"W, 810.85 feet to the POINT OF BEGINNING and containing 66.57 acres of land

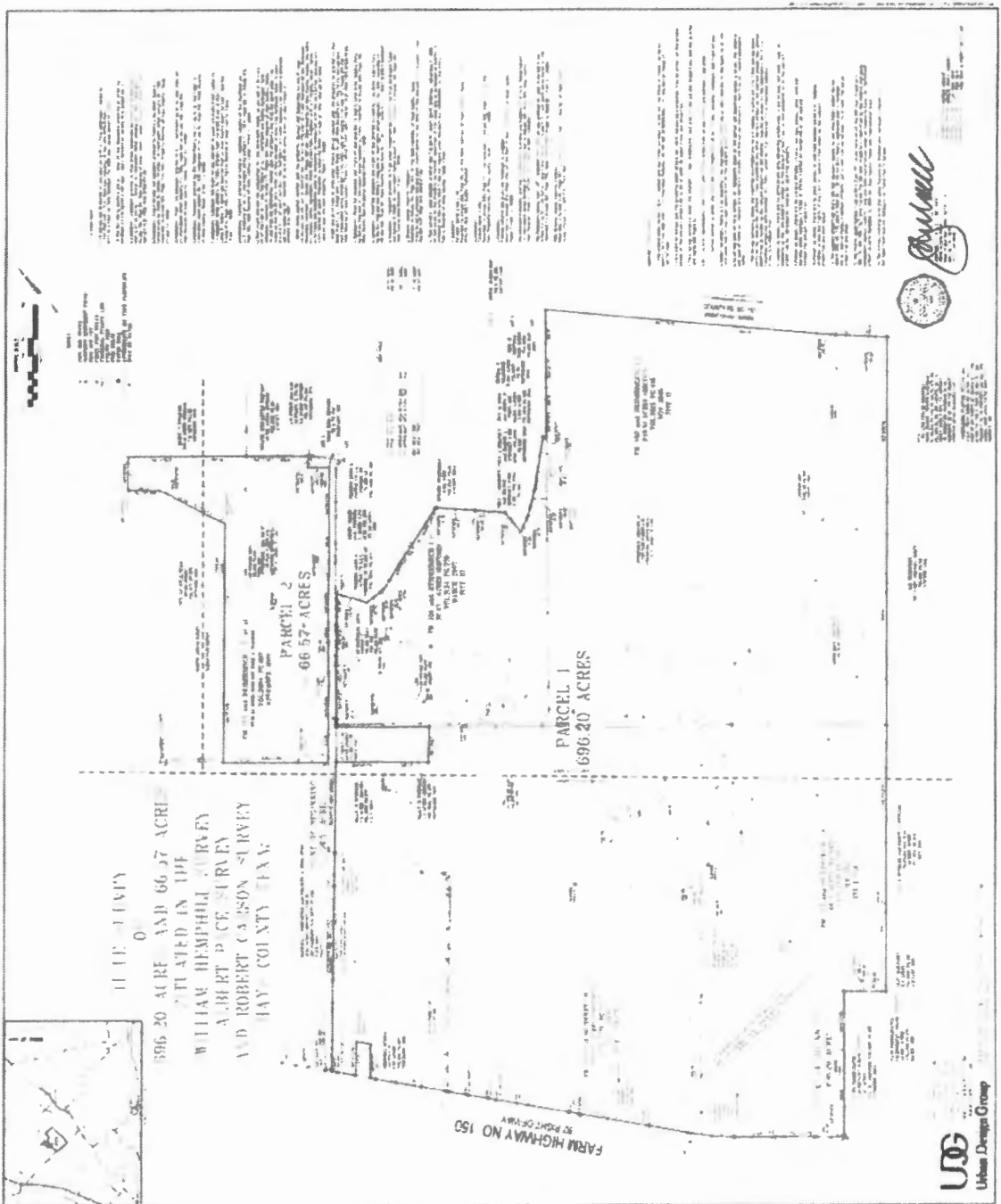

EXHIBIT H
UTILITY EXHIBIT

